

0CD10-M61300EN

# PREFACE

1. This Parts Catalog is the 1st edition of YGC6,10SS-WCM Diesel Engine for SHIN MITSUBISHI CATERPILLAR.

Pub. No. : 000Y00D6130

Published : January,1997

2. Model name

Engine model	Vehicle		Vehicle made by
	Products	Model name	
YGC6,10SS-WCM	COMPRESSOR	—	SHIN MITSUBISHI CATERPILLAR

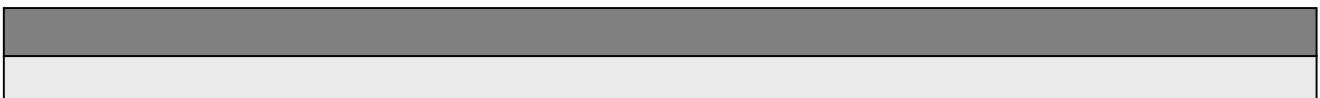

## Directions for the Parts Catalog.

1. This Parts Catalog shows both standard and optional parts.
2. Parts may change without prior notice.
3. The following is an example of the Parts Catalog format.

REF.	LEV.	PARTS NO.	DESCRIPTION	Q'TY						I	R
				(A)	(B)	(C)	(D)	(E)	(F)		
1	1	729595-51390	FUEL INJECTION PUMP	1	1	1	1	1			1
1-1	1	729595-51391	FUEL INJECTION PUMP	1	1	1	1	1		N	1
		(A=E00185) (B=E00200)									
3	2	26022-060162	SCREW M 6X 16	9	9	9	9	9			
3-1	2	26022-060162	SCREW M 6X 16	4	4	4	4	4		K	
		(A=E00156) (B=E00156) (C=E00156) (D=E00156) (E=E00156)									
4	2	129470-51040	CAMSHAFT	1	1	1	1	1			
5	2	122710-51050	BEARING, ROLLER	2	2	2	2	2			
6	2	129470-51060	RETAINER	1	1	1	1	1			

Remarks
(1) BOOST COMPEMSATOR TYPE. OPTIONAL PART, TO E00155,(4JH-DT, 4JH-DTZ

### ① Ref. No.

The Ref. No. listed may not be in accordance with the illustration Ref. No.

(Ex.) Illustration No.

List Ref No.

1

1

(Before change)

1-1

(After change)

For interchangeable symbols N, R and K, illustrations for new parts may be abbreviated.

### ② Lev. (Level)

Level indication

The numbers below indicate the level of relativity towards the main part.

1 ----- Main parts (Assembly parts)

2 ----- Sub component included in " 1 ".

3 ----- Sub component included in " 2 ".

Note) Parts that are not for sale are partially illustrated but not listed.

### ③ Interchangeability Symbol

When a part change takes place, one of the following interchangeability symbols is indicated beside the part.

Symbol	Interchangeability	Contents note
N	Old $\begin{matrix} \leftarrow \text{Yes} \\ \text{No} \rightarrow \end{matrix}$ New	New Part is interchangeable for Old Part but Old Part is not interchangeable for New Part.
Q	Old $\begin{matrix} \leftarrow \text{No} \\ \text{Yes} \rightarrow \end{matrix}$ New	New Part is not interchangeable for Old Part but Old Part is interchangeable for New Part.
R	Old $\begin{matrix} \leftarrow \text{Yes} \\ \text{Yes} \rightarrow \end{matrix}$ New	New/ Old Parts are both interchangeable.
S	Old $\begin{matrix} \leftarrow \text{No} \\ \text{No} \rightarrow \end{matrix}$ New	New/ Old Parts are both not interchangeable.
W		Part newly added.
Z		Part discontinued.
F		Not interchangeable by a single part but interchangeable together with related parts.
K		Changes only for used parts quantities.

### ④ Effective Machine No.

When a part changes, the effective Machine No. will be indicated in the (A)-(F) column.

Product Symbol	Product No.	Product Symbol	Product No.
C	Clutch No. Compressor No.	F	Machine No. (Agricultural Equip.)
D	Drive No.	M	Machine No.
E	Engine No.		

Note 1) A date may follow the symbol. (Ex.) 1996.01

Note 2) "XXXXX" and "ZZZZZ" are for parts that could not be predicted or for engine models that could not be identified.

Note 3) (A=E00185) is the E (Engine Serial Number) for the column (A) model (in this case 4JH-DT) after the parts design change.

### ⑤ Remarks

Figures or alphabets (symbols) are entered in the remarks column.

The comments (remarks) on parts that are indicated at the bottom of the illustration are the same symbols as those stated above.

# Contents

Fig. No.	Fig. Name
YGC6,10SS-WCM	
1.	CYLINDER BLOCK(YGC6SS-WCM)
2.	CYLINDER BLOCK(YGC10SS-WCM)
3.	CYLINDER HEAD&BONNET(YGC6SS-WCM)
4.	CYLINDER HEAD&BONNET(YGC10SS-WCM)
5.	AIR CLEANER & MUFFLER
6.	CRANKSHAFT,PISTON & CAMSHAFT
7.	FUEL TANK & FUEL PIPE
8.	CARBURETOR(YGC6SS-WCM)
9.	CARBURETOR(YGC10SS-WCM)
10.	GOVERNOR & CONTROL DEVICE
11.	FLY.MAGNETO&STARTING DEVICE(YGC6SS-WCM)
12.	FLY.MAGNETO&STARTING DEVICE(YGC10SS-WCM)
13.	STARTING MOTOR(YGC10SS-WCM)
14.	TOOL & LABEL
15.	SOUND-PROOF CASE(YGC6SS-WCM)
16.	SOUND-PROOF CASE(YGC10SS-WCM)
17.	GENERATOR
18.	PANEL(YGC6SS-WCM)
19.	PANEL(YGC10SS-WCM)
20.	CYLINDER BLOCK(COMPRESSOR)(YGC6SS-WCM)
21.	CYLINDER BLOCK(COMPRESSOR)(YGC10SS-WCM)
22.	CYLINDER HEAD & AIR TANK(YGC6SS-WCM)
23.	CYLINDER HEAD & AIR TANK(YGC10SS-WCM)
24.	AIR CLEANER & DUCT(YGC6SS-WCM)

Fig. No.	Fig. Name
25.	AIR CLEANER & DUCT(YGC10SS-WCM)
26.	PISTON & CRANKSHAFT(COMPRESSOR)
27.	COOLING FAN & BREATHER
28.	TENSION CLUTCH(YGC6SS-WCM)
29.	TENSION CLUTCH(YGC10SS-WCM)

Fig.1. CYLINDER BLOCK(YGC6SS-WCM)

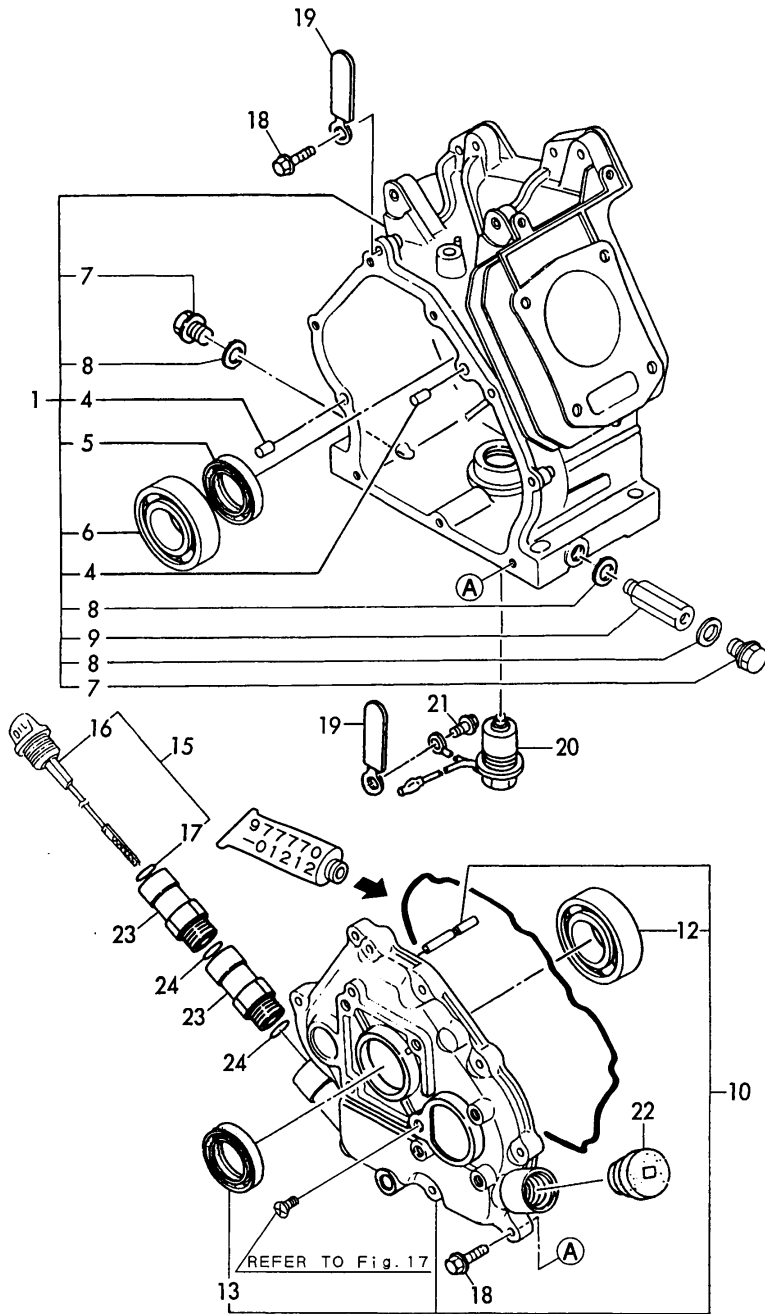

(A)=YGC6SS-WCM  
 (B)=YGC10SS-WCM  
 (C)=

(D)=  
 (E)=  
 (F)=

No.	Lev.	Parts No.	Description	Q'ty						I	R
				(A)	(B)	(C)	(D)	(E)	(F)		
1	1	760699-01640	BLOCK ASSY, CYLINDER	1							
4	2	114270-01600	PIN, M8X12	2							
5	2	160690-02220	SEAL, TC25416	1							
6	2	24101-062050	BEARING, BALL 6205C3	1							
7	2	160610-01690	PLUG, M12	2							
8	2	104200-59170	GASKET, 12	3							
9	2	160802-01700	JOINT, DRAIN	1							
10	1	760694-01501	COVER ASSY	1							
12	2	24101-062050	BEARING, BALL 6205C3	1							
13	2	160690-02220	SEAL, TC25416	1							
15	1	160591-01760	CAP ASSY	1							
16	2	160591-01750	CAP, LUB. OIL	1							
17	2	24311-000180	O-RING, 1AP18.0	1							
18	1	26476-060252	SCREW, TAPPING M6X25	8							
19	1	160260-78700	CLAMP	2							
20	1	160770-78820	SENSOR	1							
21	1	26476-060142	SCREW, TAPPING M6X14	1							
22	1	160110-01870	PLUG, RUBBER	1							
23	1	160797-01851	JOINT	2							
24	1	24311-000180	O-RING, 1AP18.0	2							

Fig.2. CYLINDER BLOCK(YGC10SS-WCM)

(A)=YGC6SS-WCM  
 (B)=YGC10SS-WCM  
 (C)=

(D)=  
 (E)=  
 (F)=

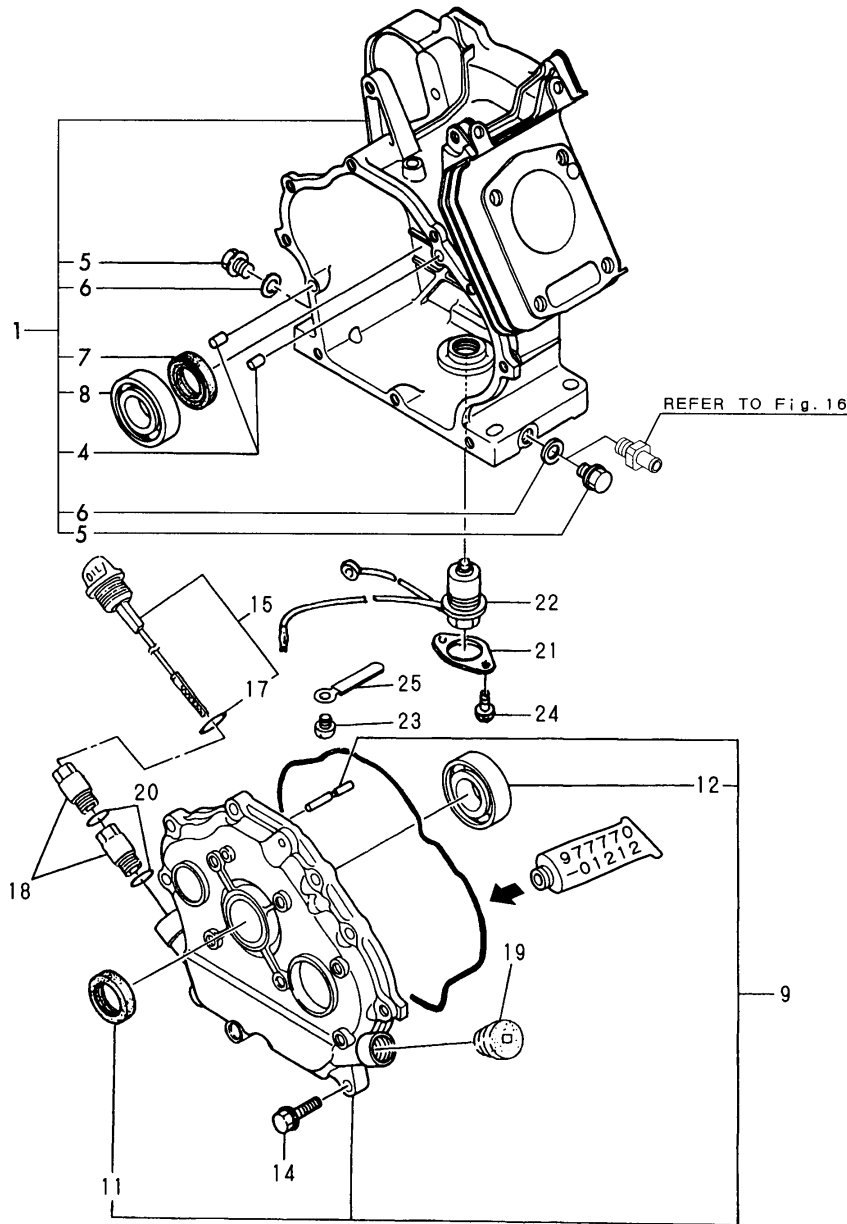

No.	Lev.	Parts No.	Description	Q'ty						I	R
				(A)	(B)	(C)	(D)	(E)	(F)		
1	1	783932-01560	BLOCK ASSY, CYLINDER		1						
4	2	114270-01600	PIN, M8X12		2						
5	2	160610-01690	PLUG, M12		2						
6	2	104200-59170	GASKET, 12		2						
7	2	160110-02220	SEAL, OIL		1						
8	2	24101-062060	BEARING, BALL 6206C3		1						
9	1	760994-01520	COVER ASSY		1						
11	2	160110-02220	SEAL, OIL		1						
12	2	24101-062060	BEARING, BALL 6206C3		1						
14	1	26106-080302	BOLT, M8X 30 PLATED		9						
15	1	160797-01760	CAP ASSY		1						
17	2	24311-000180	O-RING, 1AP18.0		1						
18	1	160797-01851	JOINT		2						
19	1	160110-01870	PLUG, RUBBER		1						
20	1	24311-000180	O-RING, 1AP18.0		2						
21	1	160797-78800	COVER		1						
22	1	160797-78810	SENSOR		1						
23	1	26476-060142	SCREW, TAPPING M6X14		1						
24	1	114351-77550	SCREW, M4X6		2						
25	1	160710-78710	CLAMP, CORD		1						

Fig.3. CYLINDER HEAD&BONNET(YGC6SS-WCM)

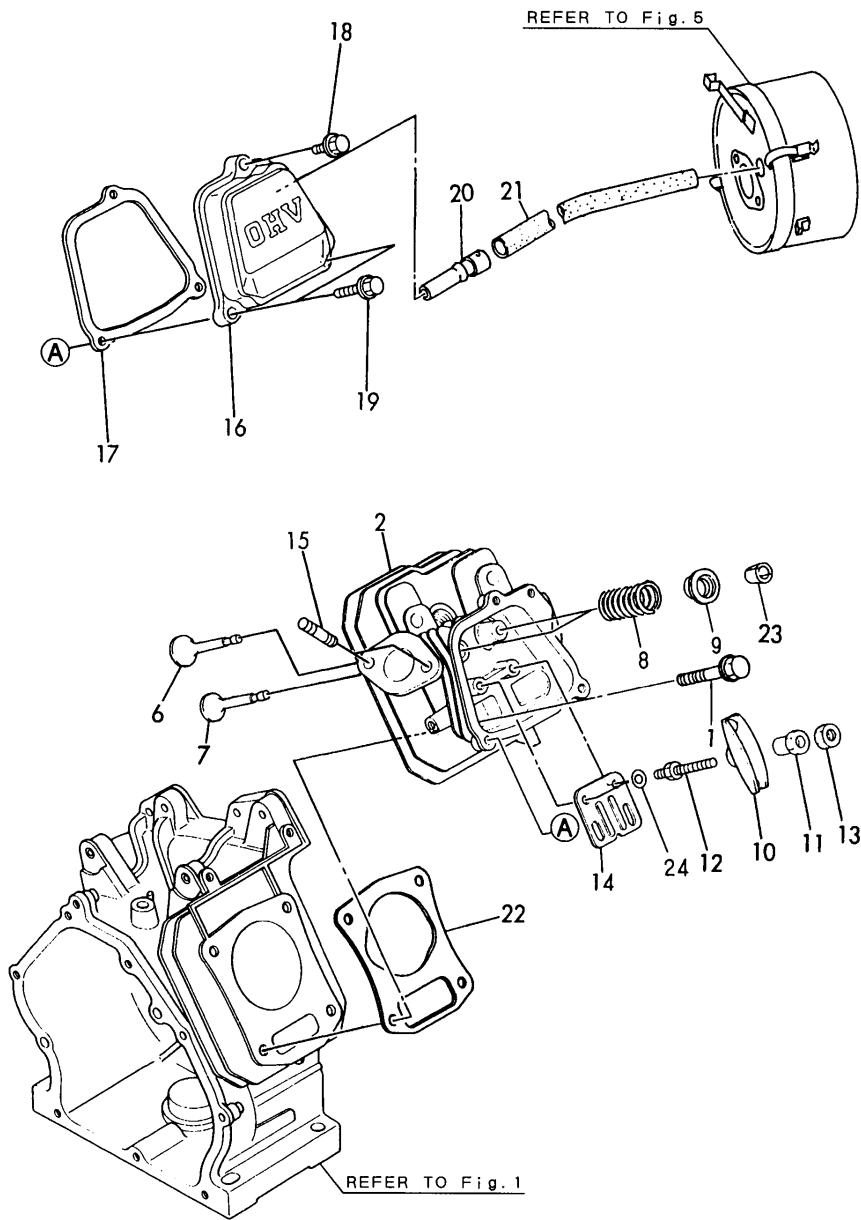

(A)=YGC6SS-WCM  
(B)=YGC10SS-WCM  
(C)=

(D)=  
(E)=  
(F)=

No.	Lev.	Parts No.	Description	Q'ty						I	R
				(A)	(B)	(C)	(D)	(E)	(F)		
1	1	160610-04201	BOLT, FLANGE M8X53	4							
2	1	160690-11010	HEAD, CYLINDER	1							
6	1	160690-11130	VALVE, INTAKE	1							
7	1	160690-11140	VALVE, EXHAUST	1							
8	1	160690-11150	SPRING, VALVE	2							
9	1	101158-11180	RETAINER, SPRING	2							
10	1	160699-11200	ARM, ROCKER	2							
11	1	160690-11220	PIVOT, ROCKER ARM	2							
11-1	1	160690-11221	PIVOT, ROCKER ARM	2							N
(A=EZZZZZ)											
12	1	160690-11271	BOLT	2							
13	1	160690-11280	NUT, M6X0.5	2							
14	1	160690-11290	PLATE, GUIDE	1							
15	1	26216-080182	STUD, M8X 18	2							
16	1	160690-11300	BONNET	1							
17	1	160690-11310	GASKET, BONNET	1							
18	1	26106-060202	BOLT, M6X 20 PLATED	1							
19	1	26106-060352	BOLT, M6X 35 PLATED	2							
20	1	160690-03050	BREATHER	1							
21	1	160810-03180	PIPE, BREATHER	1							
22	1	160699-01331	GASKET, HEAD	1							
23	1	27310-060001	COTTER, 6	2							
24	1	22137-060000	WASHER, 6	2							

Fig.4. CYLINDER HEAD&BONNET(YGC10SS-WCM)

(A)=YGC6SS-WCM  
 (B)=YGC10SS-WCM  
 (C)=

(D)=  
 (E)=  
 (F)=

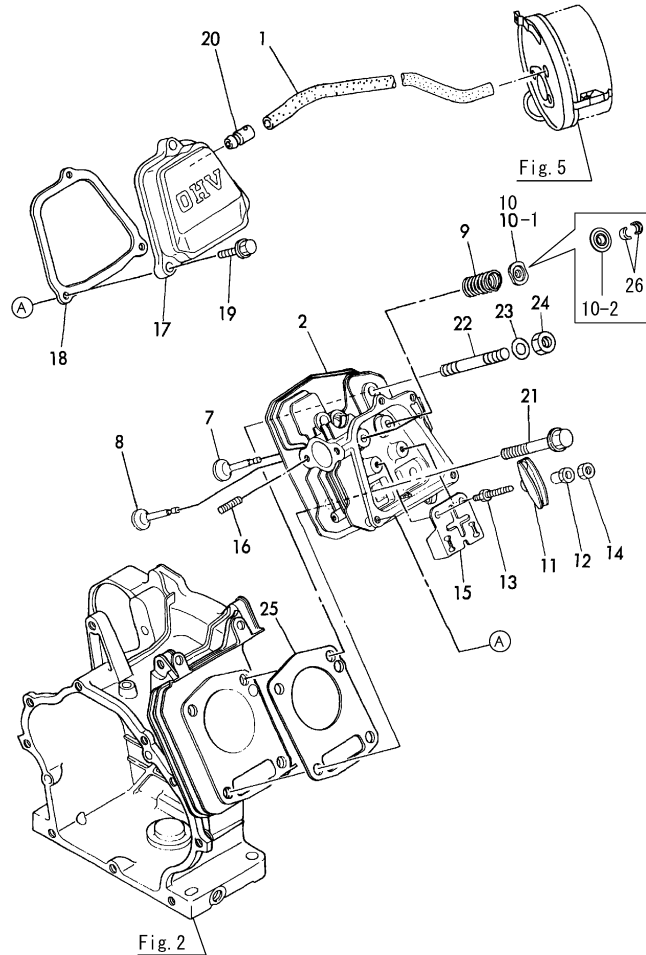

No.	Lev.	Parts No.	Description	Qty						I	R	
				(A)	(B)	(C)	(D)	(E)	(F)			
1	1	160820-03180	PIPE , BREATHER		1							
2	1	160890-11011	HEAD ASSY, CYLINDER		1							
7	1	160890-11100	VALVE, INTAKE		1							
7-1	1	160890-11101 (B=EZZZZZ)	VALVE, INTAKE		1						F	2
8	1	160890-11110	VALVE, EXHAUST		1							
8-1	1	160890-11111	VALVE, EXHAUST		1						F	2
9	1	160890-11120	SPRING, VALVE		2							
10	1	160810-11180	RETAINER, SPRING		2							
10-1	1	160890-11180 (B=EZZZZZ)	RETAINER, SPRING		2						F	1
10-2	1	160890-11190 (B=EZZZZZ)	RETAINER, SPRING		2						F	2
11	1	160890-11201	ARM, ROCKER		2							
11-1	1	160998-11200 (B=EZZZZZ)	ARM, ROCKER		2						F	1
12	1	160690-11220	PIVOT, ROCKER ARM		2							
12-1	1	160690-11221 (B=EZZZZZ)	PIVOT, ROCKER ARM		2						F	1
13	1	160690-11271	BOLT		2							
13-1	1	160890-11270 (B=EZZZZZ)	BOLT		2						F	1
14	1	160690-11280	NUT, M6X0.5		2							
15	1	160890-11290	PLATE, GUIDE		1							
16	1	26216-080182	STUD, M8X 18		2							
16-1	1	26226-080182 (B=EZZZZZ)	STUD, M8X 18		2							N
17	1	160890-11300	BONNET ASSY, HEAD		1							
18	1	160890-11310	GASKET, BONNET		1							
19	1	26106-060352	BOLT, M6X 35 PLATED		3							
20	1	160610-03050	BREATHER ASSY		1							
21	1	160890-01210	BOLT, FLANGE M10X70		2							
22	1	160998-01200	BOLT, HEAD M10		2							
23	1	26366-100002	NUT, M10		2							
24	1	105425-01250	WASHER		2							
25	1	160998-01330	GASKET, HEAD		1							
26	1	720380-11570 (B=EZZZZZ)	COTTER		2							W 2

Remarks

- (1) Ref.No.10-1,11-1,12-1 & 13-1 interchangeable by set.
- (2) Ref.No.7-1,8-1,10-2 & 26 interchangeable by set.



Fig.5. AIR CLEANER & MUFFLER

(A)=YGC6SS-WCM  
 (B)=YGC10SS-WCM  
 (C)=

(D)=  
 (E)=  
 (F)=

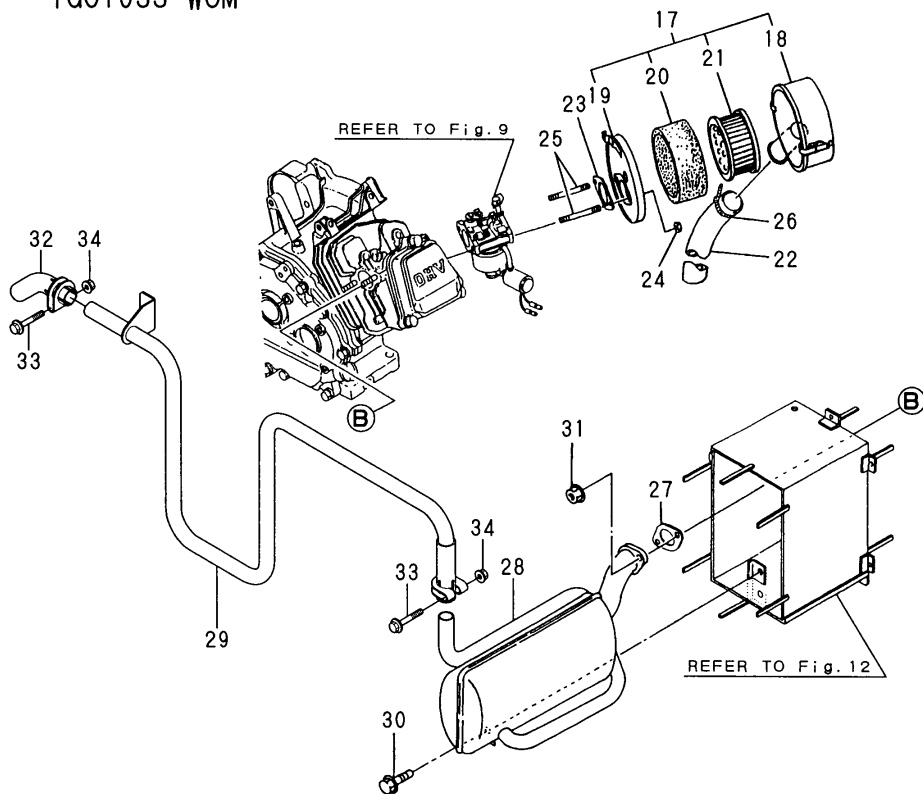
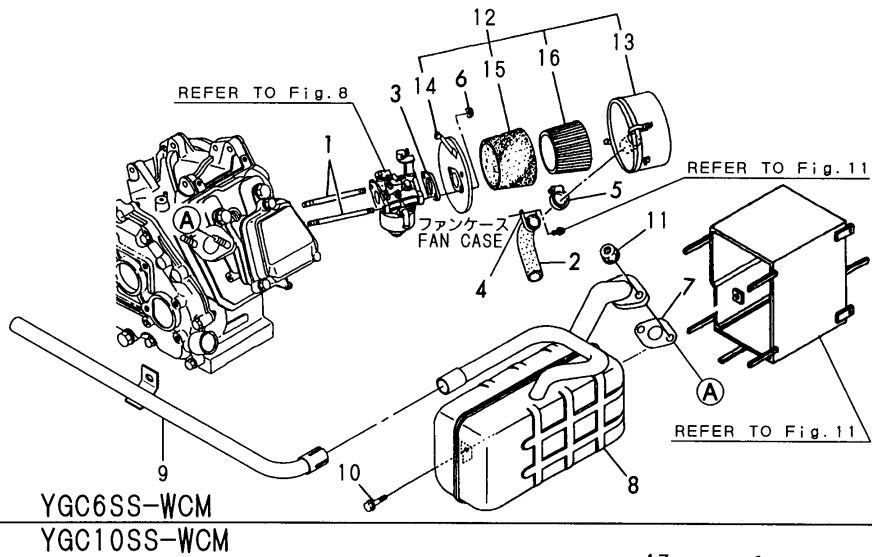

No.	Lev.	Parts No.	Description	Q'ty						I	R
				(A)	(B)	(C)	(D)	(E)	(F)		
1	1	160610-04570	BOLT, M6X70	2							
2	1	129470-49040	PIPE, WATER	1							
3	1	160610-56150	GASKET, CARBURETOR	1							
4	1	160802-78270	CLAMP, CORD	1							
5	1	23000-035000	CLAMP, 35	1							
6	1	26366-060002	NUT, M6	2							
7	1	160690-13200	GASKET, MUFFLER	1							
8	1	183702-13520	MUFFLER	1							
9	1	183702-13700	PIPE, TAIL	1							
10	1	26106-080142	BOLT, M8X 14 PLATED	1							
11	1	26366-080002	NUT, M8	2							
12	1	183702-12550	CLEANER ASSY, AIR	1							
13	2	183702-12610	BODY	1							
14	2	183702-12620	PLATE	1							
15	2	160697-12560	ELEMENT	1							
16	2	160697-12570	HOLDER, ELEMENT	1							
17	1	160998-12560	CLEANER ASSY, AIR		1						
18	2	160998-12710	BODY		1						
19	2	160998-12720	PLATE		1						
20	2	160998-12730	ELEMENT, 1ST		1						
21	2	160998-12740	ELEMENT, 2ND		1						
22	1	160998-12910	PIPE, AIR INTAKE		1						
23	1	160910-56150	GASKET, CARBURETOR		1						
24	1	26366-080002	NUT, M8		2						
25	1	26226-080802	STUD, M8X 80		2						
26	1	194250-51660	BAND, NYLON		1						
27	1	160890-13210	GASKET, MUFFLER		1						
28	1	183703-13510	MUFFLER		1						
29	1	183703-13710	PIPE, TAIL		1						
30	1	26106-080142	BOLT, M8X 14 PLATED		2						
31	1	26366-080002	NUT, M8		2						
32	1	183703-13720	DEFLECTOR		1						
33	1	26106-060402	BOLT, M6X 40 PLATED		2						
34	1	26366-060002	NUT, M6		2						

Fig.6. CRANKSHAFT,PISTON & CAMSHAFT

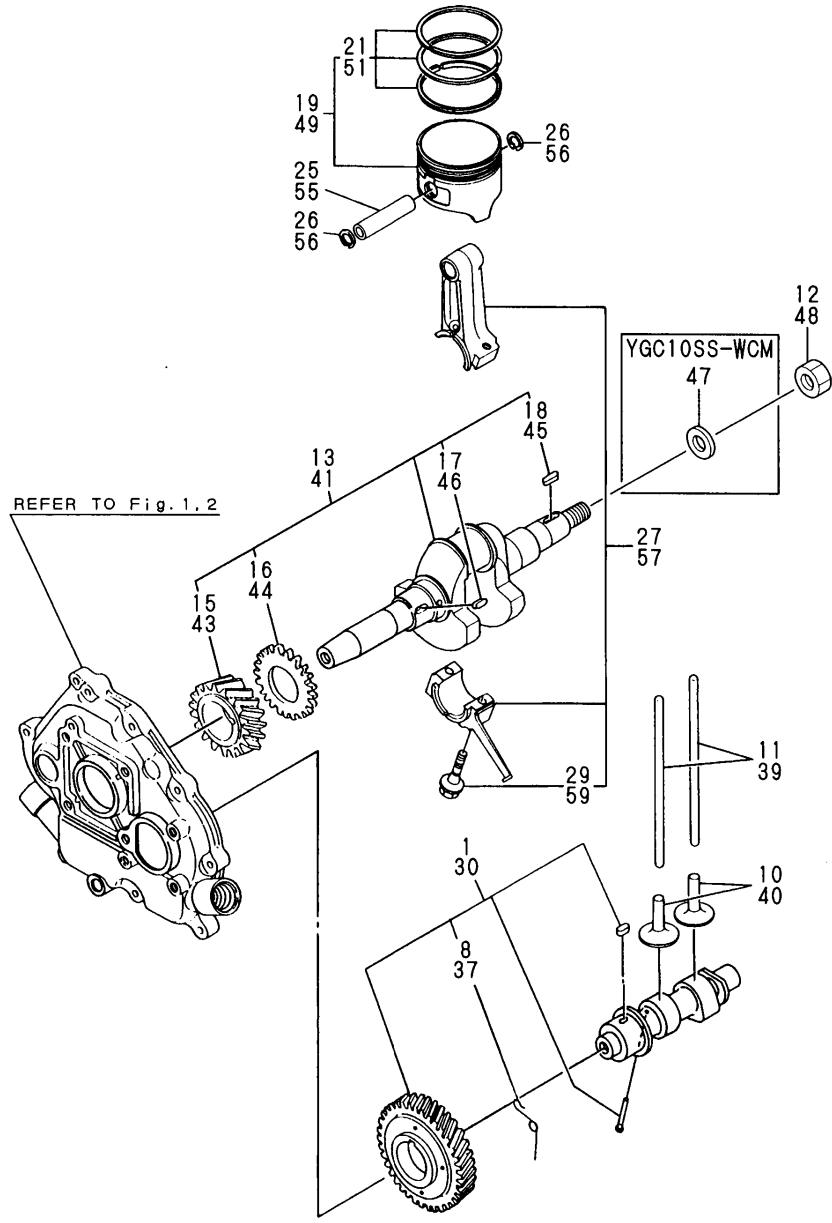

(A)=YGC6SS-WCM  
 (B)=YGC10SS-WCM  
 (C)=

(D)=  
 (E)=  
 (F)=

No.	Lev.	Parts No.	Description	Q'ty						I	R
				(A)	(B)	(C)	(D)	(E)	(F)		
1	1	160697-14050	CAMSHAFT ASSY	1							
8	2	160690-14571	SPRING,DECOMPRESSION	1							
10	1	160490-14200	TAPPET	2							
11	1	114250-14400	ROD, PUSH	2							
12	1	160610-04910	NUT, FLYWHEEL M14	1							
13	1	760694-21700	CRANKSHAFT ASSY	1							
15	2	160690-21201	GEAR, CRANKSHAFT	1							
16	2	160590-21210	GEAR, IDLE	1							
17	2	22512-040120	KEY, 4X 12	1							
18	2	22512-040160	KEY, 4X 16	1							
19	1	160699-22010	PISTON ASSY	1							
21	2	760780-22530	RING SET, PISTON	1							
25	1	160690-22300	PIN, PISTON	1							
26	1	22252-000160	RING, 16	2							
27	1	760690-23700	ROD ASSY, CONNECTING	1							
29	2	26106-060302	BOLT, M6X 30 PLATED	2							
30	1	160994-14051	CAMSHAFT ASSY					1			
37	2	160890-14560	SPRING,DECOMPRESSION					1			
39	1	160890-14400	ROD, PUSH					2			
40	1	160890-14200	TAPPET					2			
41	1	760998-21710	CRANKSHAFT ASSY					1			
43	2	160890-21200	GEAR, CRANKSHAFT					1			
44	2	160890-21220	GEAR, BALANCER					1			
45	2	22512-040160	KEY, 4X 16					1			
46	2	22512-040300	KEY, 4X 30					1			
47	1	22137-160000	WASHER, 16					1			
48	1	26737-160002	NUT, M16					1			
49	1	160998-22020	PISTON ASSY					1			
51	2	760998-22530	RING SET, PISTON					1			
55	1	160890-22300	PIN, PISTON					1			
56	1	22252-000190	RING, 19					2			
57	1	760890-23700	ROD ASSY, CONNECTING					1			
59	2	160810-23201	BOLT, CONNECTING ROD					2			

Fig.7. FUEL TANK & FUEL PIPE

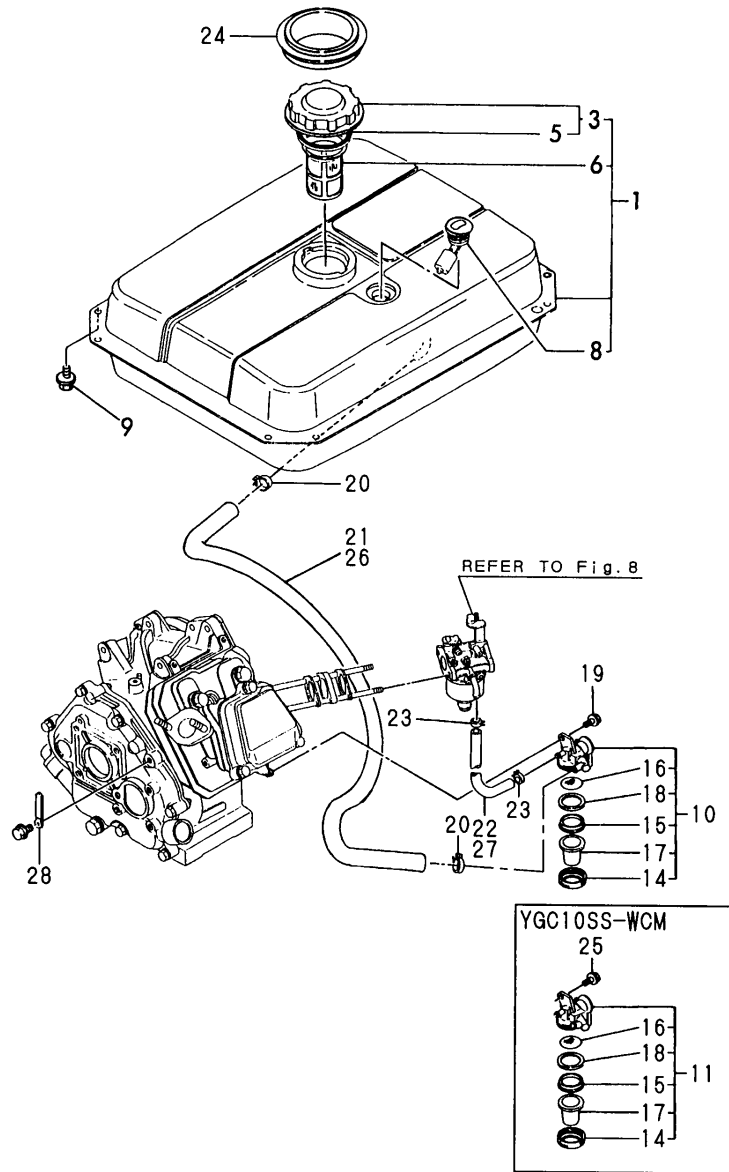

(A)=YGC6SS-WCM  
(B)=YGC10SS-WCM  
(C)=

(D)=  
(E)=  
(F)=

No.	Lev.	Parts No.	Description	Qty						I	R
				(A)	(B)	(C)	(D)	(E)	(F)		
1	1	783432-55700	TANK ASSY, FUEL	1	1						
3	2	183131-55060	CAP ASSY	1	1						
5	3	183131-55050	GASKET	1	1						
6	2	160610-55100	FILTER, FUEL	1	1						
8	2	183621-55150	GAUGE	1	1						
9	1	26106-080142	BOLT, M8X 14 PLATED	4	4						
10	1	160664-55300	COCK ASSY, FUEL	1							
11	1	160710-55301	COCK ASSY, FUEL		1						
14	2	160710-55360	RING	1	1						
15	2	160710-55370	GASKET	1	1						
16	2	160710-55381	FILTER, FUEL	1	1						
17	2	160710-55390	CUP, FUEL COCK L37	1	1						
18	2	160692-55421	PLATE		1	1					
19	1	26106-060082	BOLT, M6X 8 PLATED	1							
20	1	106990-44660	CLIP, HOSE 12.5	2	2						
21	1	160693-59350	PIPE, FUEL A-282	1							
22	1	160792-59360	PIPE, FUEL	1							
23	1	124060-77680	CLIP, HOSE 10	2	2						
24	1	183366-55210	GROMMET	1	1						
25	1	26106-060102	BOLT, M6X 10 PLATED		1						
26	1	160730-59370	PIPE, FUEL		1						
27	1	160769-59370	PIPE, FUEL L=203		1						
28	1	194440-51620	CLAMP		2						

Fig.8. CARBURETOR(YGC6SS-WCM)

(A)=YGC6SS-WCM  
 (B)=YGC10SS-WCM  
 (C)=

(D)=  
 (E)=  
 (F)=

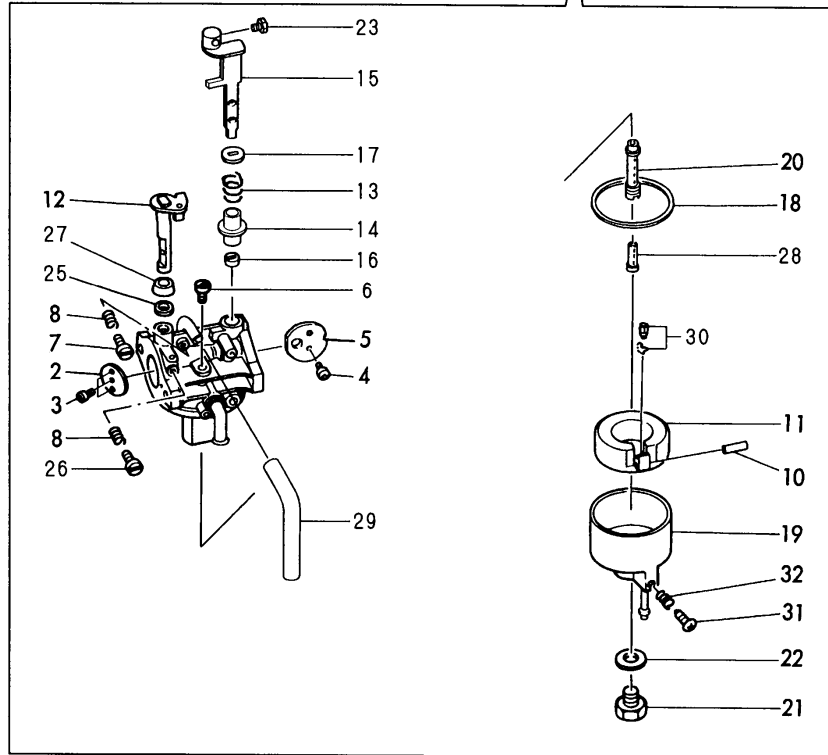
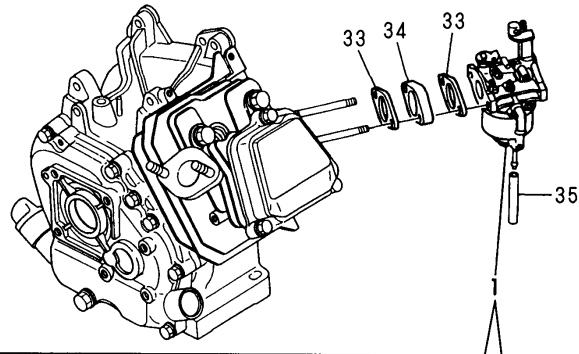

No.	Lev.	Parts No.	Description	Qty						I	R
				(A)	(B)	(C)	(D)	(E)	(F)		
1	1	160699-56050	CARBURETOR ASSY	1							
2	2	160698-56820	VALVE, THROTTLE	1							
3	2	160120-56670	SCREW	2							
4	2	160903-56670	SCREW	2							
5	2	160593-56530	VALVE, CHOKE	1							
6	2	160330-56740	JET, PILOT	1							
7	2	160692-56710	SCREW	1							
8	2	181230-56380	SPRING	2							
10	2	160610-56630	PIN, FLOAT	1							
11	2	160697-56620	FLOAT ASSY	1							
12	2	160698-56550	SHAFT, THROTTLE	1							
13	2	160594-56810	SPRING	1							
14	2	160692-56800	RUBBER, SEAL	1							
15	2	160594-56650	LEVER, CHOKE	1							
16	2	160810-56580	RING, CHOKE SHAFT	1							
17	2	160594-56590	RING, CHOKE LEVER	1							
18	2	160610-56610	GASKET	1							
19	2	160730-56640	BODY, FLOAT CHAMBER	1							
20	2	160693-56570	NOZZLE, MAIN	1							
21	2	160610-56660	BOLT	1							
22	2	160610-56611	GASKET	1							
23	2	26117-040088	BOLT M 4X 8 PLATED	1							
25	2	160640-56850	SEAL	1							
26	2	160667-56750	ADJUSTER	1							
27	2	160702-56720	RING	1							
28	2	160590-56800	NOZZLE, MAIN	1							
29	2	160692-56770	HOSE	1							
30	2	160692-56560	VALVE ASSY, NEEDLE	1							1
31	2	160610-56900	SCREW	1							
32	2	181230-56380	SPRING	1							
33	1	160610-56150	GASKET, CARBURETOR	2							
34	1	160690-56160	SPACER, CARBURETOR	1							
35	1	160730-56880	HOSE, D5/3	1							

Remarks  
 (1)REPAIR PARTS.

Fig.9. CARBURETOR(YGC10SS-WCM)

(A)=YGC6SS-WCM  
(B)=YGC10SS-WCM  
(C)=

(D)=  
(E)=  
(F)=

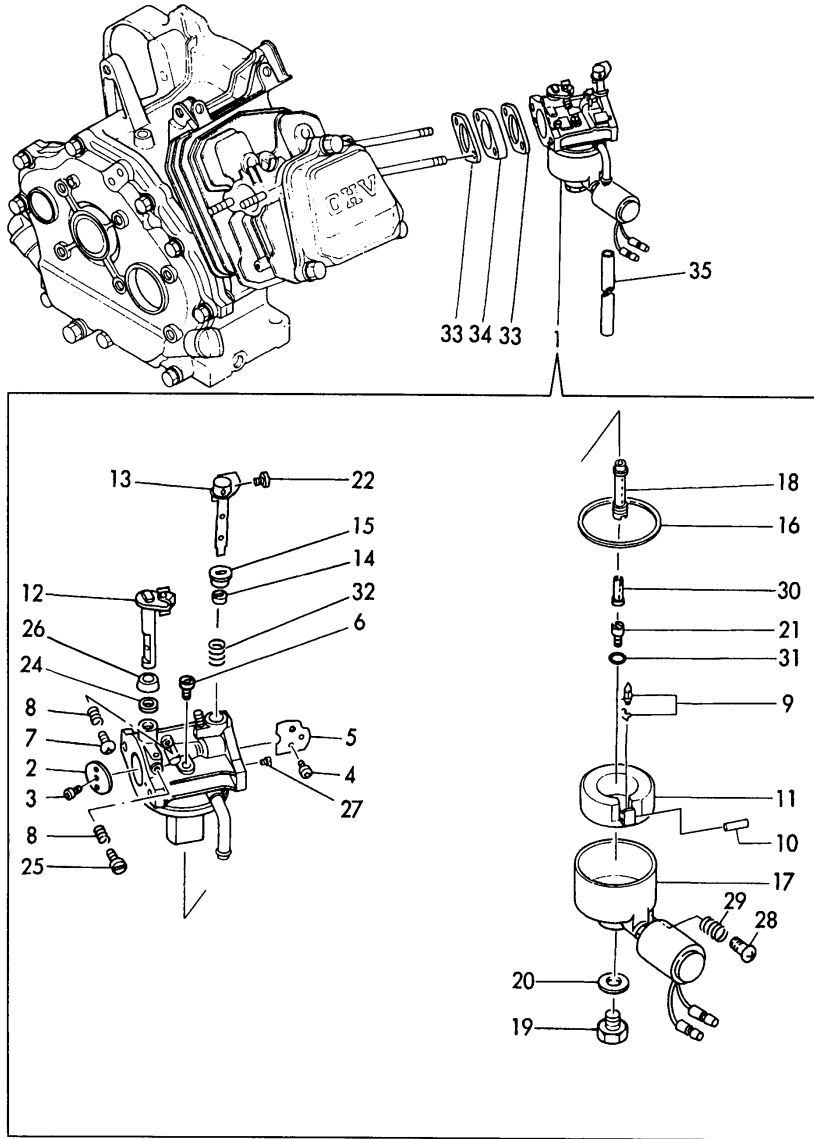

No.	Lev.	Parts No.	Description	Q'ty						I	R
				(A)	(B)	(C)	(D)	(E)	(F)		
1	1	160998-56040	CARBURETOR ASSY		1						
2	2	160992-56520	VALVE, THROTTLE		1						
3	2	160120-56670	SCREW		2						
4	2	160903-56670	SCREW		2						
5	2	160998-56620	VALVE, CHOKE		1						
6	2	160998-56630	JET, PILOT		1						
7	2	160692-56710	SCREW		1						
8	2	181230-56380	SPRING		2						
9	2	160792-56670	VALVE ASSY, NEEDLE		1						1
10	2	160610-56630	PIN, FLOAT		1						
11	2	160890-56620	FLOAT ASSY		1						
12	2	160998-56610	SHAFT, THROTTLE		1						
13	2	160998-56640	LEVER, CHOKE		1						
14	2	160810-56580	RING, CHOKE SHAFT		1						
15	2	160891-56530	RING, CHOKE LEVER		1						
16	2	160210-56610	WASHER		1						
17	2	160998-56650	SEAL		1						
18	2	160998-56660	NOZZLE, MAIN		1						
19	2	160998-56670	HOLDER		1						
20	2	160998-56680	WASHER		1						
21	2	160998-56690	JET, MAIN		1						
22	2	26117-040088	BOLT M 4X 8 PLATED		1						
24	2	160640-56850	SEAL		1						
25	2	160667-56750	ADJUSTER		1						
26	2	160702-56720	RING		1						
27	2	160790-56610	BOLT		1						
28	2	160998-56700	SCREW		1						
29	2	160211-56950	SPRING		1						
30	2	160790-56571	NOZZLE		1						
31	2	160998-56710	O-RING		1						
32	2	160998-56720	SPRING		1						
33	1	160910-56150	GASKET, CARBURETOR		2						
34	1	160890-56160	INSULATOR		1						
35	1	160730-56880	HOSE, D5/3		1						

Remarks  
1)REPAIR PART.

Fig.10. GOVERNOR & CONTROL DEVICE

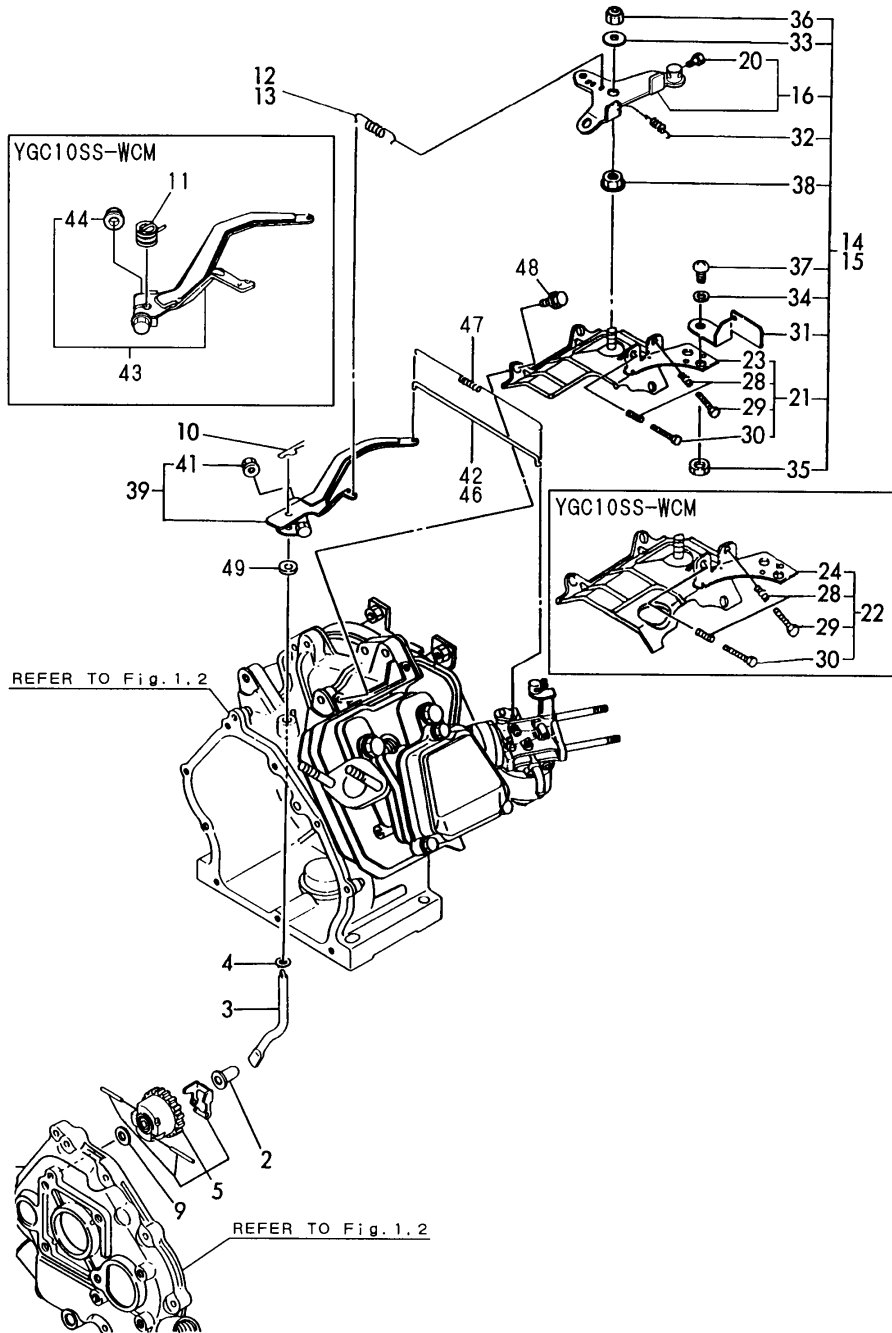

(A)=YGC6SS-WCM  
(B)=YGC10SS-WCM  
(C)=

(D)=  
(E)=  
(F)=

No.	Lev.	Parts No.	Description	Q'ty						I	R
				(A)	(B)	(C)	(D)	(E)	(F)		
2	1	160690-61301	SPINDLE	1	1						
3	1	160690-61311	SHAFT	1	1						
4	1	160690-61450	WASHER	1	1						
5	1	160690-61600	GEAR ASSY, GOVERNOR	1	1						
9	1	160120-76940	WASHER	1	1						
10	1	22372-080000	PIN, SNAP 8	1							
11	1	160890-66050	SPRING, RETURN		1						
12	1	160697-66010	SPRING, GOVERNOR	1							
13	1	160897-66010	SPRING, GOVERNOR		1						
14	1	160697-66100	CONTROLLER ASSY	1							
15	1	160797-66200	CONTROLLER ASSY		1						
16	2	160692-66051	LEVER ASSY, CONTROL	1	1						
20	3	26117-040088	BOLT M 4X 8 PLATED	1	1						
21	2	160697-66110	BASE ASSY	1							
22	2	160797-66210	BASE ASSY		1						
23	3	160697-66121	BASE ASSY	1							
24	3	160797-66221	BASE ASSY		1						
28	3	160520-66291	SPRING	2	2						
29	3	26117-040257	BOLT, M4X 25 PLATED	1	1						
30	3	26117-040357	BOLT, M4X 35 PLATED	1	1						
31	2	160797-66310	LEVER, CONTROL	1	1						
32	2	160797-66320	SPRING, CONTROL	1	1						
33	2	160670-66350	COLLAR	1	1						
34	2	22137-040000	WASHER, 4	1	1						
35	2	26347-040002	NUT, M4	1	1						
36	2	26347-060002	NUT, M6	1	1						
37	2	26557-040102	SCREW, M4X10	1	1						
38	2	26366-060002	NUT, M6	1	1						
39	1	160690-66180	LEVER ASSY, GOVERNOR	1							
41	2	26366-060002	NUT, M6	1							
42	1	160690-66200	LINK, THROTTLE	1							
43	1	160890-66190	LEVER ASSY, GOVERNOR		1						
44	2	26366-060002	NUT, M6		1						
46	1	160998-66200	LINK, THROTTLE		1						
47	1	160690-66210	SPRING, TENSION	1	1						
48	1	26476-060142	SCREW, TAPPING M6X14	3	3						
49	1	114770-61600	SEAL, OIL	1	1						

Fig.11. FLY.MAGNETO&STARTING DEVICE(YGC6SS-WCM)

(A)=YGC6SS-WCM  
(B)=YGC10SS-WCM  
(C)=

(D)=  
(E)=  
(F)=

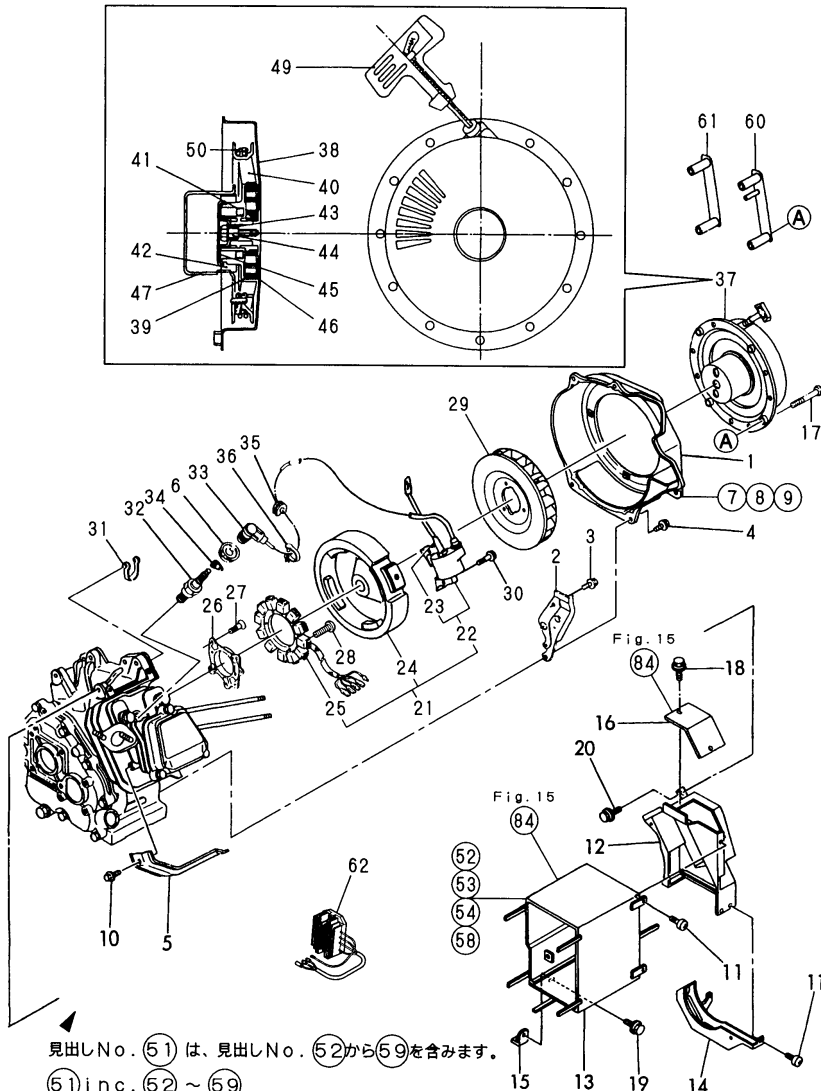

見出しNo. (51) は、見出しNo. (52)から(59)を含みます。

(51) inc. (52) ~ (59)

(REFER TO Fig.15-(55)(56)(57)(59))

注) 図番を○で囲んでいるものは、内側に付けるスポンジ又はグラスウールを示しています。  
NOTE) THE ENCIRCLED DAWING NUMBERS INDICATES THE PARTS LINED WITH RUBBER SPONGE OR GLASS WOOL.

No.	Lev.	Parts No.	Description	Q'ty						I	R
				(A)	(B)	(C)	(D)	(E)	(F)		
1	1	183702-45011	CASE, COOLING FAN	1							
2	1	160690-45211	COVER	1							
3	1	26476-060142	SCREW, TAPPING M6X14	1							
4	1	26476-060142	SCREW, TAPPING M6X14	4							
5	1	160690-45200	COVER	1							
6	1	160797-45230	COVER	1							
7	1	160697-45900	SEAL, 0.2X50X400	1							
8	1	160897-45920	SPONGE	2							
9	1	160897-45930	SPONGE	2							
10	1	26476-060142	SCREW, TAPPING M6X14	1							
11	1	26106-060122	BOLT, M6X 12 PLATED	3							
12	1	183702-45050	DUCT, COOLING	1							
13	1	183702-45060	DUCT, COOLING	1							
14	1	183702-45070	DUCT, COOLING	1							
15	1	183702-45150	STAY, DUCT	1							
16	1	183732-45540	COVER	1							
17	1	183702-76910	SCREW, M6X55	4							
18	1	26106-060102	BOLT, M6X 10 PLATED	2							
19	1	26106-060122	BOLT, M6X 12 PLATED	3							
20	1	26476-060142	SCREW, TAPPING M6X14	3							
21	1	160699-78060	MAGNETIC ASSY	1							
22	2	160690-78532	COIL, IGNITION	1							
23	3	160690-78230	WIRE	1							
24	2	160699-78520	ROTOR	1							
25	2	160798-78560	STATOR	1							
26	1	160940-78701	PLATE, COIL	1							
27	1	26577-060122	SCREW, M6X12	4							
28	1	26557-060222	SCREW M 6X 22	4							
29	1	160699-45010	CASE, COOLING FAN	1							
30	1	26476-060302	SCREW, TAPPING M6X30	2							
31	1	29610-000650	CLAMP, SPEED 065	1							
32	1	160793-78010	PLUG, SPARK	1							
33	1	160700-78040	CAP, PLUG	1							
34	1	160700-78050	TERMINAL, PLUG	1							
35	1	160700-78720	GROMMET	1							
36	1	29610-000950	CLAMP, SPEED 095	1							
37	1	183702-76050	STARTER ASSY, RECOIL	1							
38	2	183702-76500	STARTER ASSY, RECOIL	1							
39	2	160697-76510	SPRING	1							
40	2	160697-76520	REEL	1							
41	2	160641-76530	SPRING, DOG	2							
42	2	160890-76540	DOG	2							
43	2	160697-76550	SPRING, BRAKE	1							
44	2	160641-76570	SCREW	1							
45	2	160697-76570	RETAINER	1							
46	2	160697-76630	CASE, SPRING	1							
47	2	183702-76590	PULLEY, STARTER	1							
49	2	160900-76620	HANDLE	1							
50	2	160697-76580	ROPE, STARTER	1							
51	1	183702-95710	INSULATOR ASSY	1							
52	2	183732-95750	INSULATOR	1							

Remarks  
 THE ENCIRCLED DAWING NUMBER  
 (REF.NO.55,56,57,59,84) IS SEE  
 FIG.15.

Fig.11. FLY.MAGNETO&STARTING DEVICE(YGC6SS-WCM)

(A)=YGC6SS-WCM  
 (B)=YGC10SS-WCM  
 (C)=

(D)=  
 (E)=  
 (F)=

No.	Lev.	Parts No.	Description	Qty						I	R
				(A)	(B)	(C)	(D)	(E)	(F)		
53	2	183732-95760	INSULATOR	1							
54	2	183702-95780	INSULATOR	1							
55	2	183702-95770	INSULATOR	1							
56	2	183702-95760	INSULATOR	1							
57	2	183702-95750	INSULATOR	1							
58	2	183702-95790	INSULATOR	1							
59	2	183702-95800	INSULATOR	1							
60	1	183702-76601	SPACER, RECOIL	1							
61	1	183702-76610	SPACER, RECOIL	1							
62	1	183232-77520	REGULATOR, RS2713	1							

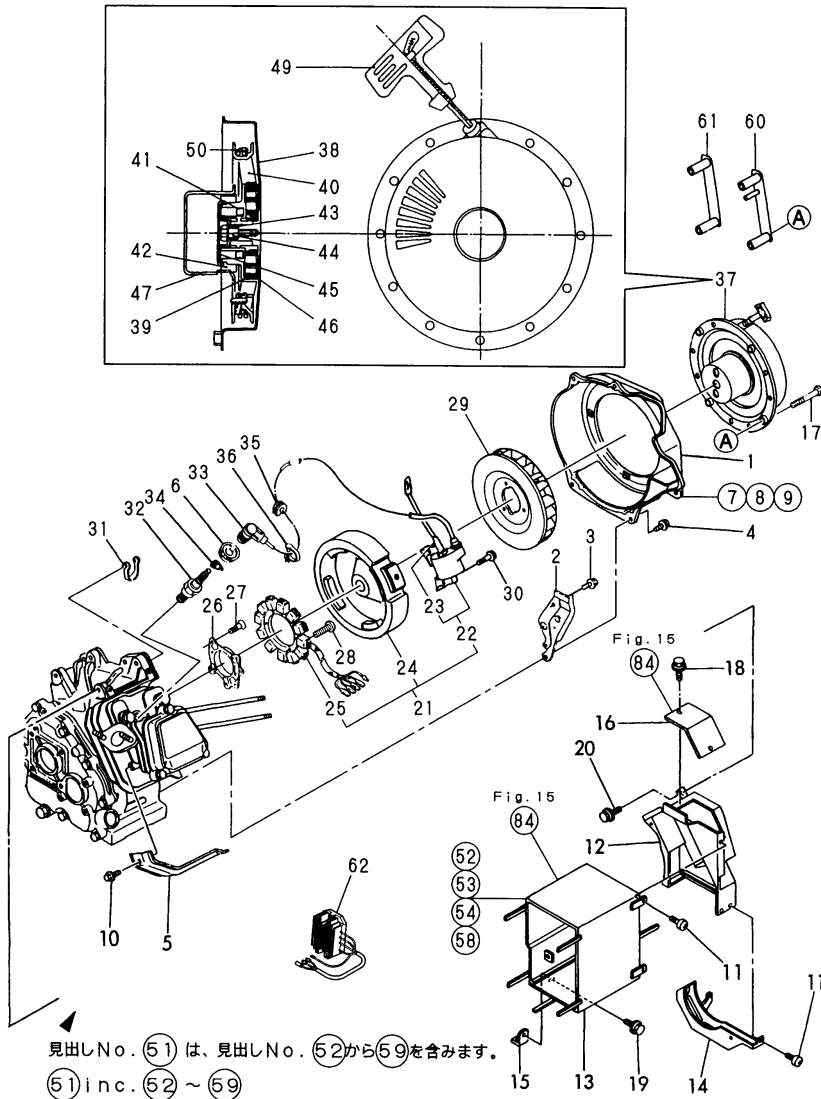

見出しNo. ⑤1 は、見出しNo. ⑤2から⑤9を含みます。

⑤1 inc. ⑤2 ~ ⑤9

(REFER TO Fig. 15-⑤5⑤6⑤7⑤9)

注) 図番を○で囲んでいるものは、内側に付けるスポンジ又はグラスウールを示しています。  
 NOTE) THE ENCIRCLED DRAWING NUMBERS INDICATES THE PARTS LINED WITH RUBBER SPONGE OR GLASS WOOL.

Remarks  
 THE ENCIRCLED DRAWING NUMBER  
 (REF.NO.55,56,57,59,84) IS SEE  
 FIG. 15.



Fig.12. FLY.MAGNETO&STARTING DEVICE(YGC10SS-WCM)

(A)=YGC6SS-WCM  
(B)=YGC10SS-WCM  
(C)=

(D)=  
(E)=  
(F)=

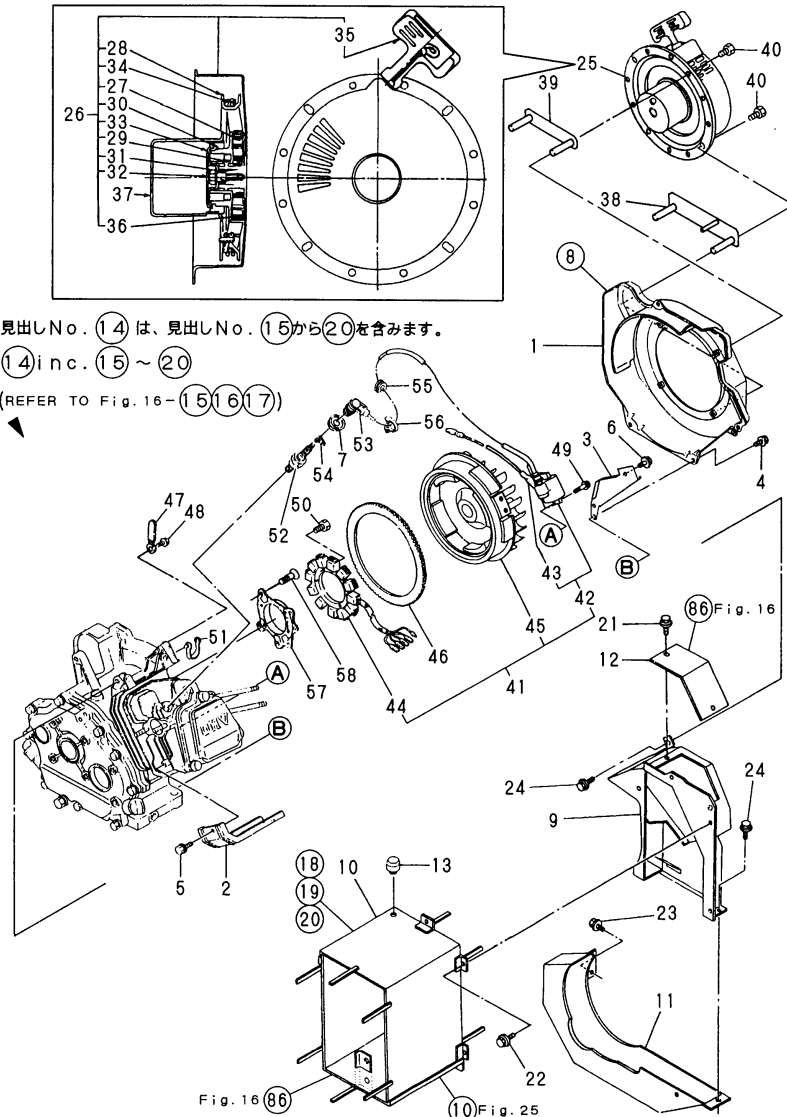

見出しNo. ⑭は、見出しNo. ⑮から⑳を含みます。

⑭inc. ⑮～⑳

(REFER TO Fig. 16-⑮⑯⑰)

注) 図番を○で囲んでいるものは、内側に付けるスポンジ又はガラスウールを示しています。  
NOTE) THE ENCIRCLED DAWING NUMBERS INDICATES THE PARTS LINED WITH RUBBER SPONGE OR GLASS WOOL.

No.	Lev.	Parts No.	Description	Q'ty						I	R
				(A)	(B)	(C)	(D)	(E)	(F)		
1	1	160897-45130	CASE, COOLING FAN	1							
2	1	160890-45200	COVER, HEAD	1							
3	1	160998-45210	COVER	1							
4	1	26476-060142	SCREW, TAPPING M6X14	4							
5	1	26476-060142	SCREW, TAPPING M6X14	2							
6	1	26476-060142	SCREW, TAPPING M6X14	1							
7	1	160797-45230	COVER	1							
8	1	160897-45920	SPONGE	2							
9	1	183703-45080	DUCT, COOLING	1							
10	1	183703-45060	DUCT, COOLING	1							
11	1	183703-45090	DUCT, COOLING	1							
12	1	183833-45200	COVER	1							
13	1	160720-55530	DAMPER	1							
14	1	183703-95710	INSULATOR ASSY	1							
15	2	183703-95770	INSULATOR	1							
16	2	183703-95780	INSULATOR	1							
17	2	183703-85790	INSULATOR	1							
18	2	183703-95740	INSULATOR	2							
19	2	183703-95750	INSULATOR	1							
20	2	183703-95760	INSULATOR	1							
21	1	26106-060102	BOLT, M6X 10 PLATED	4							
22	1	26106-060122	BOLT, M6X 12 PLATED	6							
23	1	26106-080142	BOLT, M8X 14 PLATED	1							
24	1	26476-060142	SCREW, TAPPING M6X14	2							
25	1	183703-76060	STARTER ASSY, RECOIL	1							
26	2	183703-76260	STARTER ASSY, RECOIL	1							
27	3	160697-76510	SPRING	1							
28	3	160797-76520	REEL	1							
29	3	160641-76550	SPRING, DOG	2							
30	3	160890-76540	DOG	2							
31	3	160697-76550	SPRING, BRAKE	1							
32	3	160641-76570	SCREW	1							
33	3	160697-76570	RETAINER	1							
34	3	160797-76580	ROPE, STARTER	1							
35	3	160260-76620	KNOB, STARTER	1							
36	3	160697-76630	CASE, SPRING	1							
37	2	160998-76590	PULLEY, STARTER	1							
38	1	183703-76600	SPACER, RECOIL A	1							
39	1	183703-76610	SPACER, RECOIL B	1							
40	1	26106-060552	BOLT, M6X 55 PLATED	4							
41	1	183703-78060	MAGNETIC ASSY	1							
42	2	160797-78522	COIL, IGNITION	1							
43	3	160690-78230	WIRE	1							
44	2	160998-78590	STATOR	1							
45	2	183703-78550	ROTOR	1							
46	1	160794-78150	GEAR, RING	1							
47	1	160710-78710	CLAMP, CORD	2							
48	1	26476-060142	SCREW, TAPPING M6X14	2							
49	1	26476-060252	SCREW, TAPPING M6X25	2							
50	1	26557-060222	SCREW M 6X 22	4							
51	1	29610-000650	CLAMP, SPEED 065	1							

Remarks  
THE ENCIRCLED DAWING NUMBER  
(REF NO.15,16,17,86)IS SEE FIG.16  
THE ENCIRCLED DAWING NUMBER  
(REF NO.10)IS SEE FIG.25

Fig.12. FLY.MAGNETO&STARTING DEVICE(YGC10SS-WCM)

(A)=YGC6SS-WCM  
(B)=YGC10SS-WCM  
(C)=

(D)=  
(E)=  
(F)=

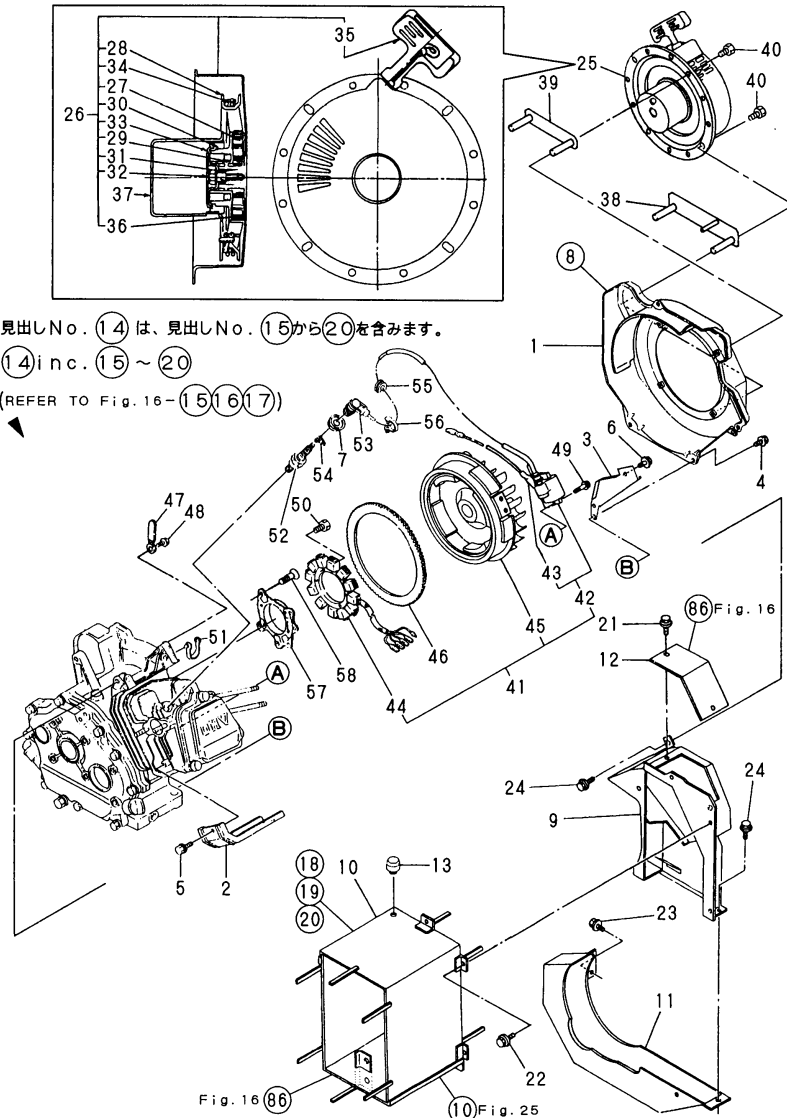

見出しNo. ⑭は、見出しNo. ⑮から⑳を含みます。

⑭inc. ⑮～⑳

(REFER TO Fig.16-⑮⑯⑰)

注) 図番を○で囲んでいるものは、内側に付けるスポンジ又はガラスウールを示しています。  
NOTE) THE ENCIRCLED DAWING NUMBERS INDICATES THE PARTS LINED WITH RUBBER SPONGE OR GLASS WOOL.

No.	Lev.	Parts No.	Description	Q'ty						I	R
				(A)	(B)	(C)	(D)	(E)	(F)		
52	1	160998-78010	PLUG, SPARK		1						
53	1	160700-78040	CAP, PLUG		1						
54	1	160700-78050	TERMINAL, PLUG		1						
55	1	160700-78720	GROMMET		1						
56	1	29610-000950	CLAMP, SPEED 095		1						
57	1	160940-78701	PLATE, COIL		1						
58	1	26557-060122	SCREW, M6X12		4						

Remarks  
THE ENCIRCLED DAWING NUMBER  
(REF NO.15,16,17,86)IS SEE FIG.16  
THE ENCIRCLED DAWING NUMBER  
(REF NO.10)IS SEE FIG.25

Fig.13. STARTING MOTOR(YGC10SS-WCM)

(A)=YGC6SS-WCM  
 (B)=YGC10SS-WCM  
 (C)=

(D)=  
 (E)=  
 (F)=

No.	Lev.	Parts No.	Description	Q'ty						I	R
				(A)	(B)	(C)	(D)	(E)	(F)		
1	1	114362-77011	STARTER		1						
2	2	114381-77110	ARMATURE		1						
3	2	X2114811000	WASHER KIT, THRUST		1						
4	2	X2114715500	STOPPER SET		1						
5	2	114381-77130	COIL ASSY, FIELD		1						
6	2	114381-77140	COVER		1						
7	2	114371-77160	HOLDER ASSY, BRUSH		1						
8	3	114371-79040	BRUSH		2						
9	3	114371-79050	BRUSH		1						
10	3	114371-79060	SPRING		4						
11	2	X2114455080	PINION ASSY		1						
12	2	114381-77150	HOUSING ASSY, GEAR		1						
13	2	114371-77170	COVER ASSY, DUST		1						
14	2	X2114560130	LEVER KIT, SHIFT		1						
15	2	X2114275010	SWITCH ASSY		1						
16	2	X2114680050	BOLT, THROUGH		2						
17	2	114371-79070	BOLT		2						
18	2	X2114274200	COVER		1						
19	1	26106-100302	BOLT, M10X 30 PLATED		2						
20	1	160671-78200	WIRE, LEAD		1						

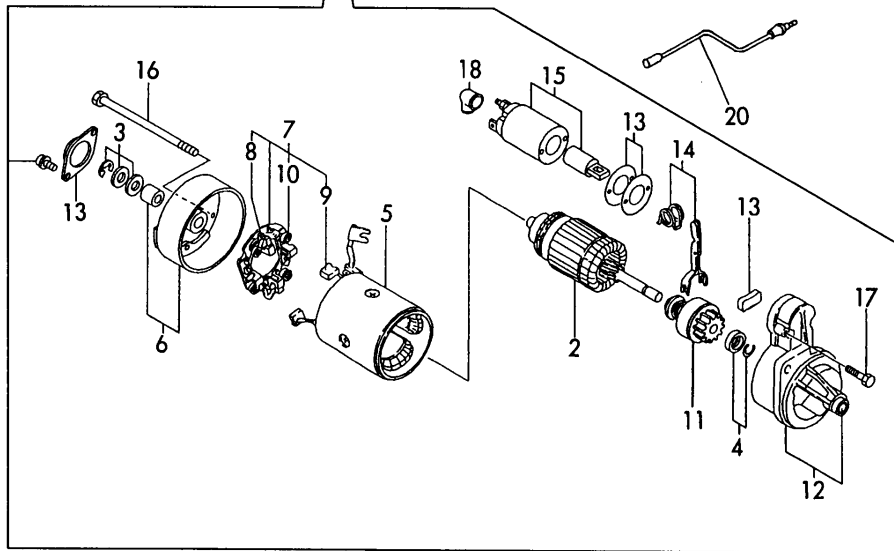
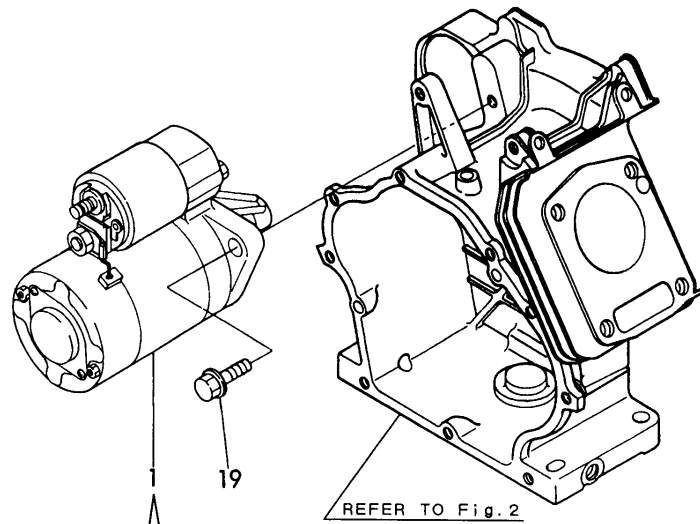
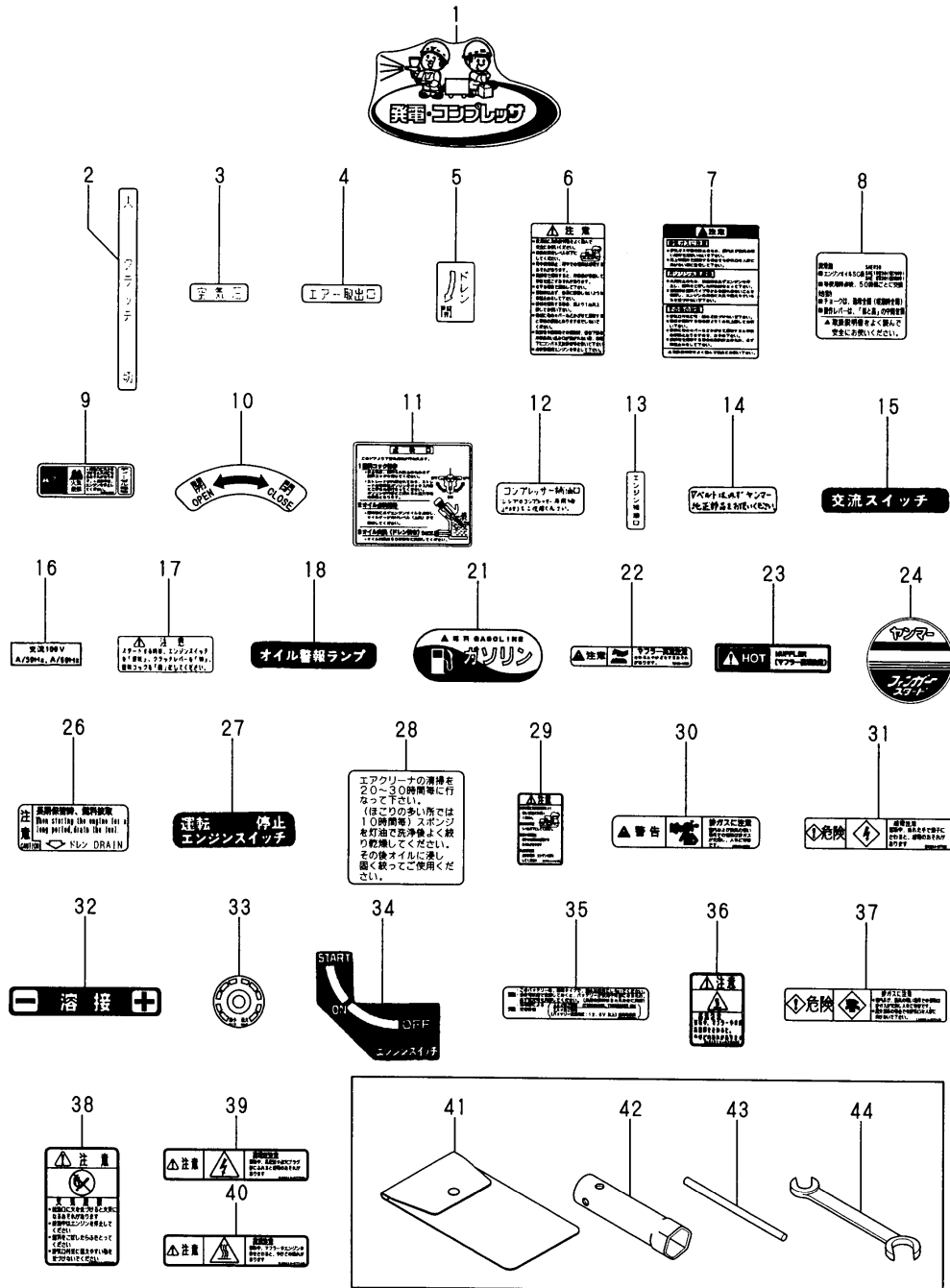

Fig.14. TOOL & LABEL

(A)=YGC6SS-WCM  
(B)=YGC10SS-WCM  
(C)=

(D)=  
(E)=  
(F)=



No.	Lev.	Parts No.	Description	Q'ty						I	R
				(A)	(B)	(C)	(D)	(E)	(F)		
1	1	183702-07440	LABEL	1	1						
2	1	183702-07100	LABEL	1	1						
3	1	183702-07110	LABEL	1	1						
4	1	183702-07120	LABEL	1	1						
5	1	183702-07130	LABEL	1	1						
6	1	183632-07600	LABEL, CAUTION	1							
7	1	183101-07250	LABEL, CAUTION		1						
8	1	160692-07250	LABEL, CAUTION	1							
9	1	160690-07320	LABEL, NO FIRE	1							
10	1	183702-07350	LABEL, DOOR	1	2						
11	1	183131-07360	LABEL, CHECK	1	1						
12	1	183702-07400	LABEL	1	1						
13	1	183702-07410	LABEL	1	1						
14	1	183702-07420	LABEL	1	1						
15	1	183730-07430	LABEL, AC SWITCH	1	1						
16	1	183731-07450	LABEL, AMPERE	1	1						
17	1	183702-07460	LABEL	1	1						
18	1	183730-07470	LABEL, OIL ALERT	1	1						
21	1	183332-07420	LABEL, GASOLINE	1	1						
22	1	105250-07330	LABEL	1							
23	1	170001-07230	LABEL, CAUTION		1						
24	1	160699-07200	LABEL, FINGER START	1							
26	1	160520-07272	LABEL, DRAIN	1							
27	1	183730-07420	LABEL, ENGINE SWITCH	1							
28	1	160520-07370	LABEL, CLEANER	1							
29	1	183614-07750	LABEL, CAUTION	1							
30	1	105250-07340	LABEL, EXH. GAS CAUTN	1							
31	1	183614-07700	LABEL, CAUTION		1						
32	1	183131-07410	LABEL, TERMINAL	1							
33	1	183701-07900	LABEL	1							
34	1	183131-07450	LABEL, KEY SWITCH	1							
35	1	183131-07600	LABEL	1							
36	1	183211-07580	LABEL, MUFFLER	1	1						
37	1	183614-07710	LABEL, EXH. GAS CAUTN	1	1						
38	1	183614-07720	LABEL, NO FIRE	1	1						
39	1	183614-07730	LABEL, PLUG	1	1						
40	1	183614-07740	LABEL, CAUTION	1	1						
41	1	160110-92610	BAG, TOOL	1	1						
42	1	160120-92700	WRENCH, 21 L86	1	1						
43	1	160110-92710	HANDLE, WRENCH	1	1						
44	1	28110-100120	SPANNER, 10X12	1	1						

Fig.15. SOUND-PROOF CASE(YGC6SS-WCM)

(A)=YGC6SS-WCM  
(B)=YGC10SS-WCM  
(C)=

(D)=  
(E)=  
(F)=

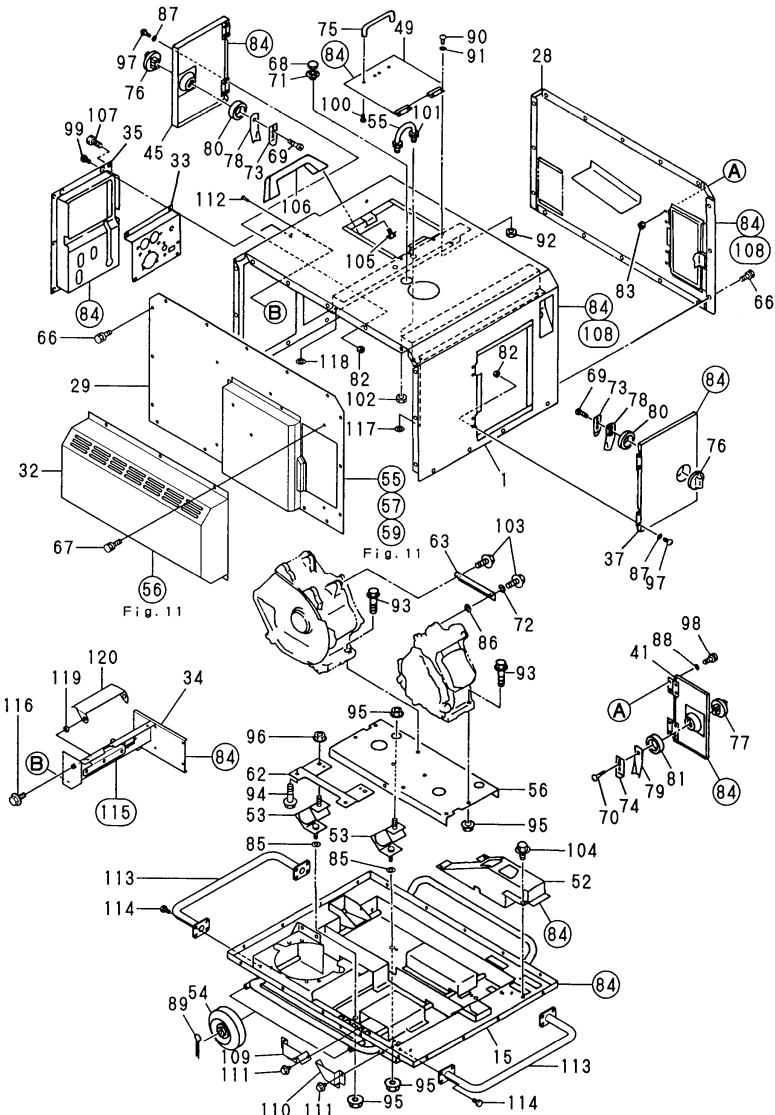

注) 図番を○で囲んでいるものは、内側に付けるスポンジ又はグラスウールを示しています。  
NOTE) THE ENCIRCLED DRAWING NUMBERS INDICATES THE PARTS LINED WITH RUBBER SPONGE OR GLASS WOOL.

No.	Lev.	Parts No.	Description	Q'ty						I	R
				(A)	(B)	(C)	(D)	(E)	(F)		
1	1	183702-08301-1	CASE ASSY	1							
15	1	183702-08311-1	CASE	1							
28	1	183702-08071-1	CASE ASSY	1							
29	1	183702-08321-1	CASE ASSY	1							
32	1	183702-08331-1	CASE, MUFFLER	1							
33	1	183702-08180	PANEL	1							
34	1	183702-08190	PANEL ASSY	1							
35	1	183702-08111	PANEL ASSY	1							
37	1	183702-08120-1	DOOR ASSY, ENGINE	1							
41	1	183702-08130-1	DOOR	1							
45	1	183702-08170-1	DOOR	1							
49	1	183702-08150-1	DOOR, AIR CLEANER	1							
52	1	183702-08160-1	GUIDE	1							
53	1	183250-08220	DAMPER	4							
54	1	183266-08360	WHEEL, 100	4							
55	1	183833-08490	HOOK	1							
56	1	183702-08550-1	COMMON BED	1							
62	1	183702-08580	STAY, AIR CLEANER	1							
63	1	183701-08570	STIFFENER	1							
66	1	183732-08900	BOLT	40							
67	1	183732-08900	BOLT	6							
68	1	183131-08910	WINDOW	1							
69	1	183732-08910	SCREW, M5X16	2							
70	1	183732-08910	SCREW, M5X16	1							
71	1	183131-08920	GROMMET	1							
72	1	160510-14550	WASHER	1							
73	1	1E6910-35660	PLATE, STOPPER	2							
74	1	1E6910-35660	PLATE, STOPPER	1							
75	1	183632-55050	KNOB	1							
76	1	1E6460-91573	KNOB, SACKER	2							
77	1	1E6460-91573	KNOB, SACKER	1							
78	1	1E6460-91580	STOPPER	2							
79	1	1E6460-91580	STOPPER	1							
80	1	1E6460-91591	COLLAR, 25X32X8.6	2							
81	1	1E6460-91591	COLLAR, 25X32X8.6	1							
82	1	183925-91990	NUT, LOCK	8							
83	1	183925-91990	NUT, LOCK	4							
84	1	183702-95510	SPONGE ASSY	1							
85	1	22117-120000	WASHER, 12	4							
86	1	22137-060000	WASHER, 6	1							
87	1	22217-030000	WASHER, SPRING 3	8							
88	1	22217-030000	WASHER, SPRING 3	4							
89	1	22417-320250	PIN, COTTER 3.2X25	4							
90	1	26557-030082	SCREW, M3X 8	4							
91	1	22217-030000	WASHER, SPRING 3	4							
92	1	183925-91990	NUT, LOCK	4							
93	1	26106-080352	BOLT, M8X 35 PLATED	8							
94	1	26116-080302	BOLT, M8X 30 PLATED	2							
95	1	26366-080002	NUT, M8	9							
96	1	26366-100002	NUT, M10	8							
97	1	26557-030082	SCREW, M3X 8	8							

Remarks  
THE ENCIRCLED DRAWING NUMBER  
(REF.NO.55,56,57,59) IS SEE  
FIG.11.

Fig.15. SOUND-PROOF CASE(YGC6SS-WCM)

(A)=YGC6SS-WCM  
 (B)=YGC10SS-WCM  
 (C)=

(D)=  
 (E)=  
 (F)=

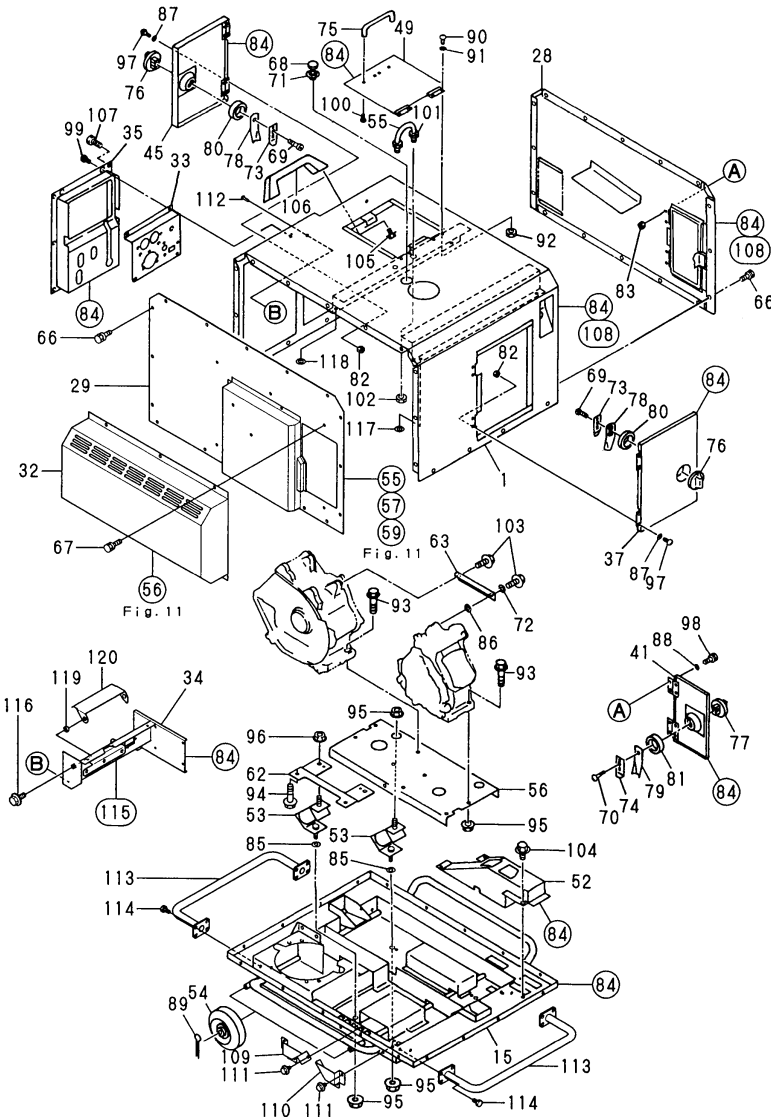

注) 図番を○で囲んでいるものは、内側に付けるスポンジ又はグラスウールを示しています。  
 NOTE) THE ENCIRCLED DRAWING NUMBERS INDICATES THE PARTS LINED WITH RUBBER SPONGE OR GLASS WOOL.

No.	Lev.	Parts No.	Description	Q'ty						I	R
				(A)	(B)	(C)	(D)	(E)	(F)		
98	1	26557-030082	SCREW, M3X 8	4							
99	1	26557-040102	SCREW, M4X10	4							
100	1	26557-050082	SCREW, M5X 8	2							
101	1	26712-100002	NUT, M10	2							
102	1	26757-100002	NUT, LOCK M10	2							
103	1	26476-060202	SCREW, TAPPING M6X20	2							
104	1	26106-060102	BOLT, M6X 10 PLATED	3							
105	1	26106-080142	BOLT, M8X 14 PLATED	2							
106	1	198220-62410	BAR, ASSIST	1							
107	1	183705-08900	BOLT	6							
108	1	183703-95540	SPONGE	3							
109	1	183702-08470	COVER	1							
110	1	183702-08480	COVER	1							
111	1	26106-060102	BOLT, M6X 10 PLATED	4							
112	1	26106-080202	BOLT, M8X 20 PLATED	2							
113	1	183702-08930	HANDLE ASSY	2							
114	1	183732-08900	BOLT	8							
115	1	183702-08910	SEAT, RUBBER	1							
116	1	26106-060142	BOLT, M6X 14 PLATED	2							
117	1	160610-55460	INSULATOR	2							
118	1	160610-55470	WASHER	2							
119	1	183131-08310	COLLAR	2							
120	1	183131-08300-1	COVER (BLUE:MW)	1							

Remarks  
 THE ENCIRCLED DRAWING NUMBER  
 (REF.NO.55,56,57,59) IS SEE  
 FIG.11.

Fig.16. SOUND-PROOF CASE(YGC10SS-WCM)

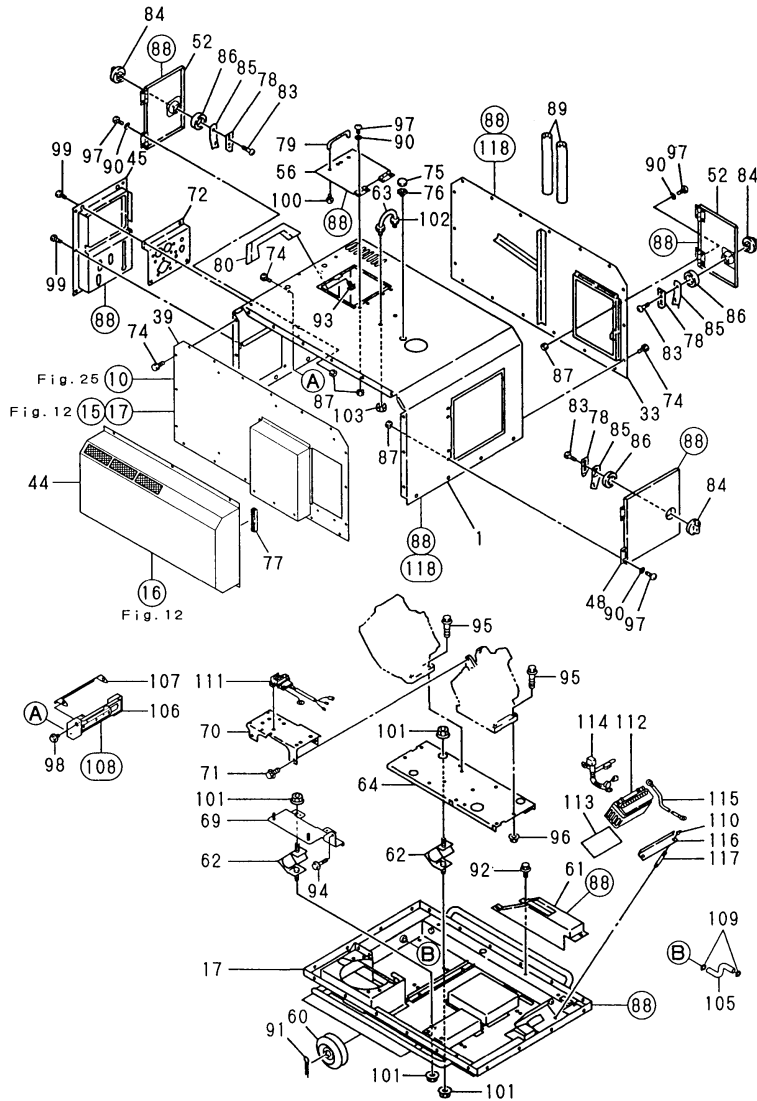

注) 図番を○で囲んでいるものは、内側に付けるスポンジ又はグラスウールを示しています。  
 NOTE) THE ENCIRCLED DAWING NUMBERS INDICATES THE PARTS LINED WITH RUBBER SPONGE OR GLASS WOOL.

Remarks  
 THE ENCIRCLED DAWING NUMBER  
 (REF NO.15,16,17)IS SEE FIG.12.  
 THE ENCIRCLED DAWING NUMBER  
 (REF NO.10)IS SEE FIG.25.

(A)=YGC6SS-WCM  
 (B)=YGC10SS-WCM  
 (C)=

(D)=  
 (E)=  
 (F)=

No.	Lev.	Parts No.	Description	Q'ty						I	R
				(A)	(B)	(C)	(D)	(E)	(F)		
1	1	183703-08300-1	CASE ASSY	1							
17	1	183703-08310-1	CASE,BOTTOM(GRAY:49)	1							
33	1	183703-08070-1	CASE ASSY	1							
39	1	183703-08320-1	CASE ASSY	1							
44	1	183703-08330-1	CASE, MUFFLER	1							
45	1	183703-08110	PANEL ASSY	1							
48	1	183703-08120-1	DOOR, ENGINE	1							
52	1	183703-08140-1	DOOR	2							
56	1	183703-08150-4	DOOR, AIR CLEANER	1							M
60	1	183671-08160	WHEEL, 130	4							
61	1	183703-08160-1	GUIDE	1							
62	1	183250-08220	DAMPER	4							
63	1	183833-08490	HOOK	1							
64	1	183703-08551-1	COMMON BED	1							
69	1	183703-08580	STAY	1							
70	1	183703-08590	STIFFENER	1							
71	1	26106-080202	BOLT, M8X 20 PLATED	2							
72	1	183703-08760	PANEL	1							
74	1	183732-08900	BOLT	44							
75	1	183131-08910	WINDOW	1							
76	1	183131-08920	GROMMET	1							
77	1	183703-08990	RUBBER, SEAL	1							
78	1	1E6910-35660	PLATE, STOPPER	3							
79	1	183632-55050	KNOB	1							
80	1	198220-62410	BAR, ASSIST	1							
83	1	1E6770-91500	SCREW, M2.5X16	3							
84	1	1E6460-91573	KNOB, SACKER	3							
85	1	1E6460-91580	STOPPER	3							
86	1	1E6460-91591	COLLAR, 25X32X8.6	3							
87	1	183925-91990	NUT, LOCK	16							
88	1	183703-95510	SPONGE ASSY	1							
89	1	183703-95530	PIPE	2							
90	1	22217-030000	WASHER, SPRING 3	16							
91	1	22417-400360	COTTER PIN 4.0X36	4							
92	1	26106-060122	BOLT, M6X 12 PLATED	3							
93	1	26106-080142	BOLT, M8X 14 PLATED	2							
94	1	26106-080352	BOLT, M8X 35 PLATED	2							
95	1	26106-080382	BOLT, M8X 38 PLATED	8							
96	1	26366-080002	NUT, M8	8							
97	1	26557-030122	SCREW, M3X12	16							
98	1	26106-080142	BOLT, M8X 14 PLATED	2							
99	1	26557-040102	SCREW, M4X10	10							
100	1	26557-050082	SCREW, M5X 8	2							
101	1	26696-100002	NUT, LOCK M10	4							
102	1	26712-100002	NUT, M10	2							
103	1	26757-100002	NUT, LOCK M10	2							
104	1	160998-01950	NIPPLE, DRAIN	2							
105	1	160998-01960	PIPE, DRAIN	2							
106	1	183703-08130	PANEL ASSY	1							
107	1	183703-08170-1	COVER, TERMINAL	1							
108	1	183703-08980	SEAT, RUBBER	1							

Fig.16. SOUND-PROOF CASE(YGC10SS-WCM)

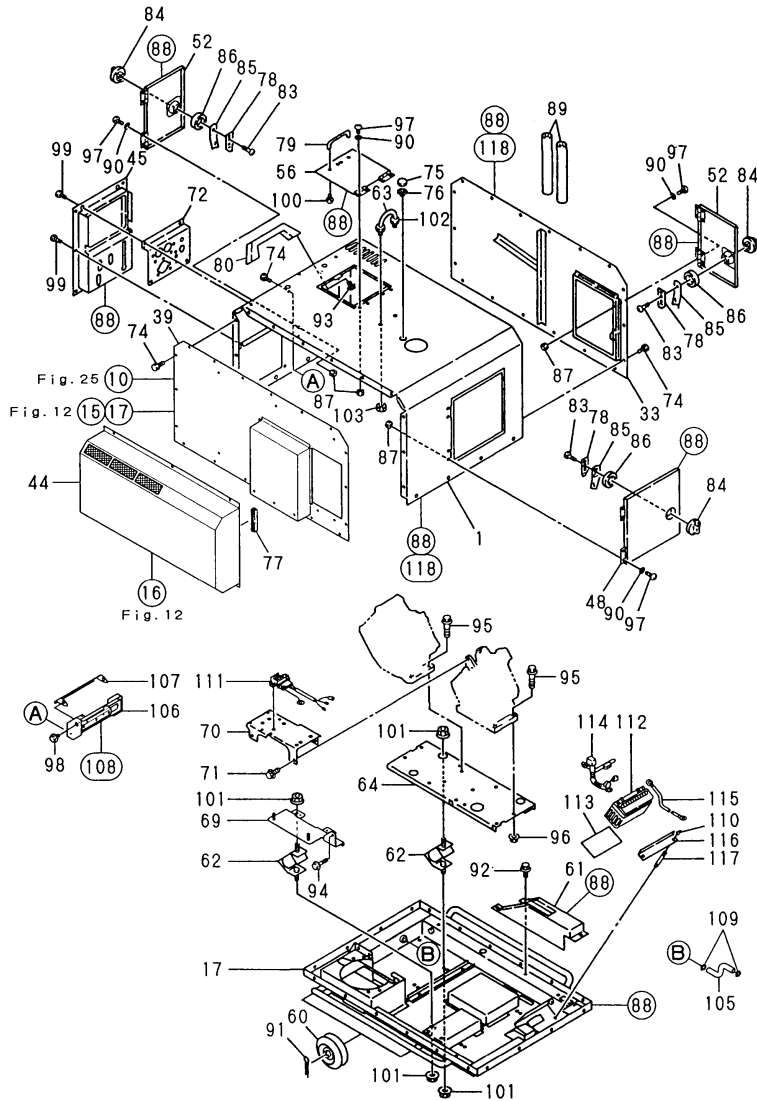

注) 図番を○で囲んでいるものは、内側に付けるスポンジ又はグラスウールを示しています。  
 NOTE) THE ENCIRCLED DAWING NUMBERS INDICATES THE PARTS LINED WITH RUBBER SPONGE OR GLASS WOOL.

Remarks  
 THE ENCIRCLED DAWING NUMBER  
 (REF NO.15,16,17)IS SEE FIG.12.  
 THE ENCIRCLED DAWING NUMBER  
 (REF NO.10)IS SEE FIG.25.

(A)=YGC6SS-WCM  
 (B)=YGC10SS-WCM  
 (C)=

(D)=  
 (E)=  
 (F)=

No.	Lev.	Parts No.	Description	Q'ty						I	R
				(A)	(B)	(C)	(D)	(E)	(F)		
109	1	106990-44660	CLIP, HOSE 12.5		4						
110	1	101147-12550	NUT		2						
111	1	183232-77520	REGULATOR, RS2713		1						
112	1	183933-79510	BATTERY, YTX12-BS		1						
113	1	183131-79550	SEAT, BATTERY		1						
114	1	183135-79550	CABLE, BATTERY +		1						
115	1	183920-79560	CABLE, -		1						
116	1	183131-79601	RETAINER, BATTERY		1						
117	1	183932-79950	STUD, M6X145		2						
118	1	183703-95540	SPONGE		4						



Fig.17. GENERATOR

(A)=YGC6SS-WCM  
(B)=YGC10SS-WCM  
(C)=

(D)=  
(E)=  
(F)=

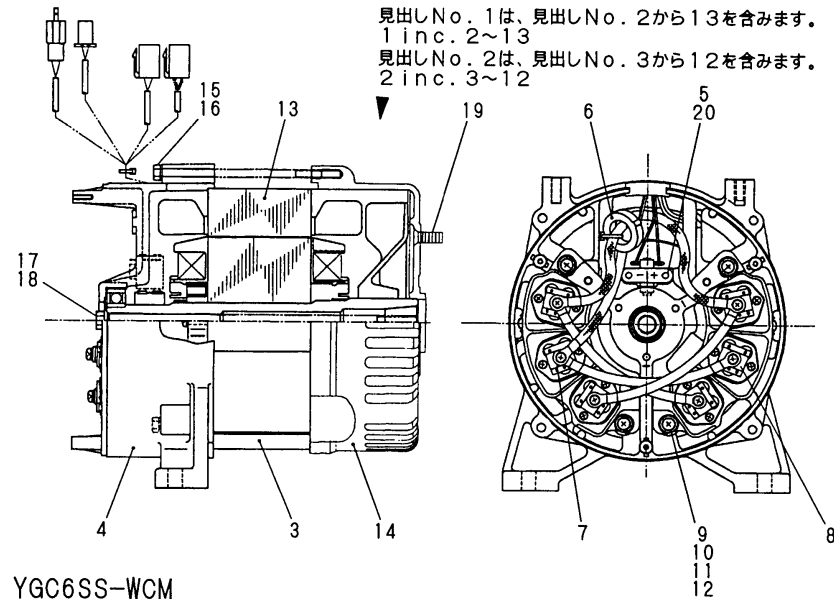

YGC6SS-WCM

YGC10SS-WCM

見出しNo. 21は、見出しNo. 22から35を含みます。  
21 inc. 22~35  
見出しNo. 22は、見出しNo. 23から34を含みます。  
22 inc. 23~34

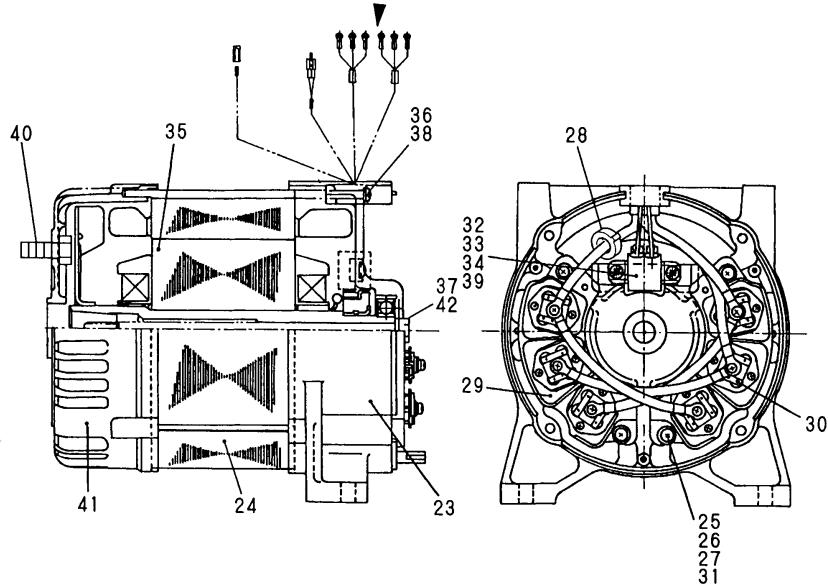

No.	Lev.	Parts No.	Description	Qty						I	R
				(A)	(B)	(C)	(D)	(E)	(F)		
1	1	183702-74050	GENERATOR	1							
2	2	183702-74200	STATOR ASSY	1							
3	3	183702-74290	STATOR	1							
4	3	183231-74280	COVER	1							
5	3	183250-74271	BRUSH ASSY	1							
5-1	3	183250-74272	BRUSH ASSY	1							N
(A=EZZZZZ)											
6	3	183702-74460	BRUSH ASSY	1							
7	3	183702-74470	DIODE ASSY	1							
8	3	183702-74480	DIODE ASSY	1							
9	3	183100-74490	BUSH	4							
10	3	183100-74380	WASHER	4							
11	3	183100-74390	WASHER	4							
12	3	183100-74320	SCREW 5X24	4							
13	2	183702-74350	ROTOR ASSY	1							
14	1	183702-74150	COVER	1							
15	1	183860-74410	SCREW, M6	4							
16	1	22217-060000	WASHER, SPRING 6	4							
17	1	22217-080000	WASHER, SPRING 8	1							
18	1	128620-18210	BOLT, M8X232	1							
19	1	183730-74950	SCREW, M8X18	4							
20	1	26023-040142	SCREW, M4X14	2							
21	1	183231-74051	GENERATOR, 140A		1						
22	2	183231-74201	STATOR ASSY		1						
23	3	183231-74280	COVER		1						
24	3	183231-74291	STATOR		1						
25	3	183100-74320	SCREW 5X24		4						
26	3	183100-74380	WASHER		4						
27	3	183100-74390	WASHER		4						
28	3	183231-74460	TRANSFORMER, CURRENT		1						
29	3	183231-74470	DIODE ASSY		1						
30	3	183231-74480	DIODE ASSY		1						
31	3	183100-74490	BUSH		4						
32	3	183250-74271	BRUSH ASSY		1						
32-1	3	183250-74272	BRUSH ASSY		1						N
(B=EZZZZZ)											
33	3	183820-74240	HOLDER, BRUSH		1						
34	3	183100-74310	SCREW 5X16		2						
35	2	183231-74350	ROTOR ASSY		1						
36	1	183860-74410	SCREW, M6		4						
37	1	183982-74430	BOLT, M10X255		1						
38	1	22217-060000	WASHER, SPRING 6		4						
39	1	26023-040142	SCREW, M4X14		2						
40	1	183730-74950	SCREW, M8X18		4						
41	1	183934-74152	COVER		1						
42	1	22217-080000	WASHER, SPRING 8		1						

Fig.18. PANEL(YGC6SS-WCM)

(A)=YGC6SS-WCM  
 (B)=YGC10SS-WCM  
 (C)=

(D)=  
 (E)=  
 (F)=

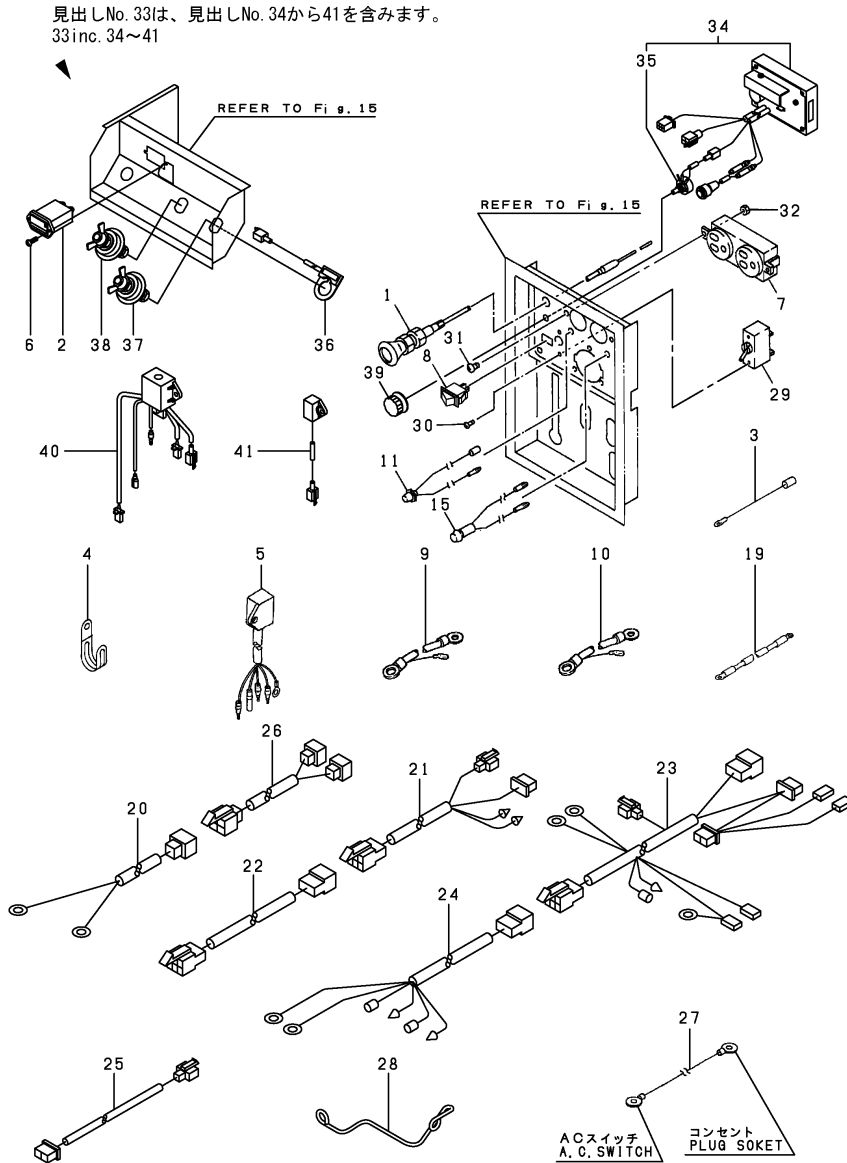

No.	Lev.	Parts No.	Description	Q'ty						I	R
				(A)	(B)	(C)	(D)	(E)	(F)		
1	1	183703-56900	WIRE ASSY, CHOKE	1							
2	1	175211-66100	METER, HOUR	1							
3	1	160671-78200	WIRE, LEAD	1							
4	1	160260-78700	CLAMP	1							
5	1	160770-78830	SENSOR	1							
6	1	26557-030122	SCREW, M3X12	2							
7	1	183920-91320	SOCKET, 125VX2	1							
8	1	183730-91450	SWITCH, STOP	1							
9	1	183135-91720	CABLE ASSY, +	1							
10	1	183135-91730	CABLE ASSY, -	1							
11	1	183732-95500	ALERT ASSY	1							
15	1	183732-95510	LAMP ASSY, PILOT	1							
19	1	183135-95630	WIRE, LEAD	1							
20	1	183702-95630	HARNESS, WIRE	1							
21	1	183702-95640	HARNESS, WIRE	1							
22	1	183702-95650	HARNESS, WIRE	1							
23	1	183702-95660	HARNESS, WIRE	1							
24	1	183702-95670	HARNESS, WIRE	1							
25	1	183702-95680	HARNESS, WIRE	1							
26	1	183702-95690	HARNESS, WIRE	1							
27	1	183130-95760	HARNESS, WIRE	1							
28	1	183702-95900	SUPPORT	1							
29	1	183000-96550	BREAKER, AC 25A	1							
30	1	26557-030062	SCREW, M3X 6	2							
31	1	26557-040062	SCREW, M4X 6	2							
32	1	26757-040002	NUT, LOCK M4	2							
33	1	183702-91050	PARTS ASSY, ELECTRIC	1							
34	2	183702-74500	REGULATOR, VOLTAGE	1							
35	3	183131-91712	RESISTOR ASSY	1							
36	2	183101-91171	SWITCH ASSY	1							
37	2	183101-91160	TERMINAL SET	1							
38	2	183101-91150	TERMINAL SET (-)	1							
39	2	183231-91690	KNOB	1							
40	2	183702-91091	CONDENSER ASSY	1							
41	2	183976-78850	TRANSFORMER, CURRENT	1							

Fig.19. PANEL(YGC10SS-WCM)

(A)=YGC6SS-WCM  
 (B)=YGC10SS-WCM  
 (C)=

(D)=  
 (E)=  
 (F)=

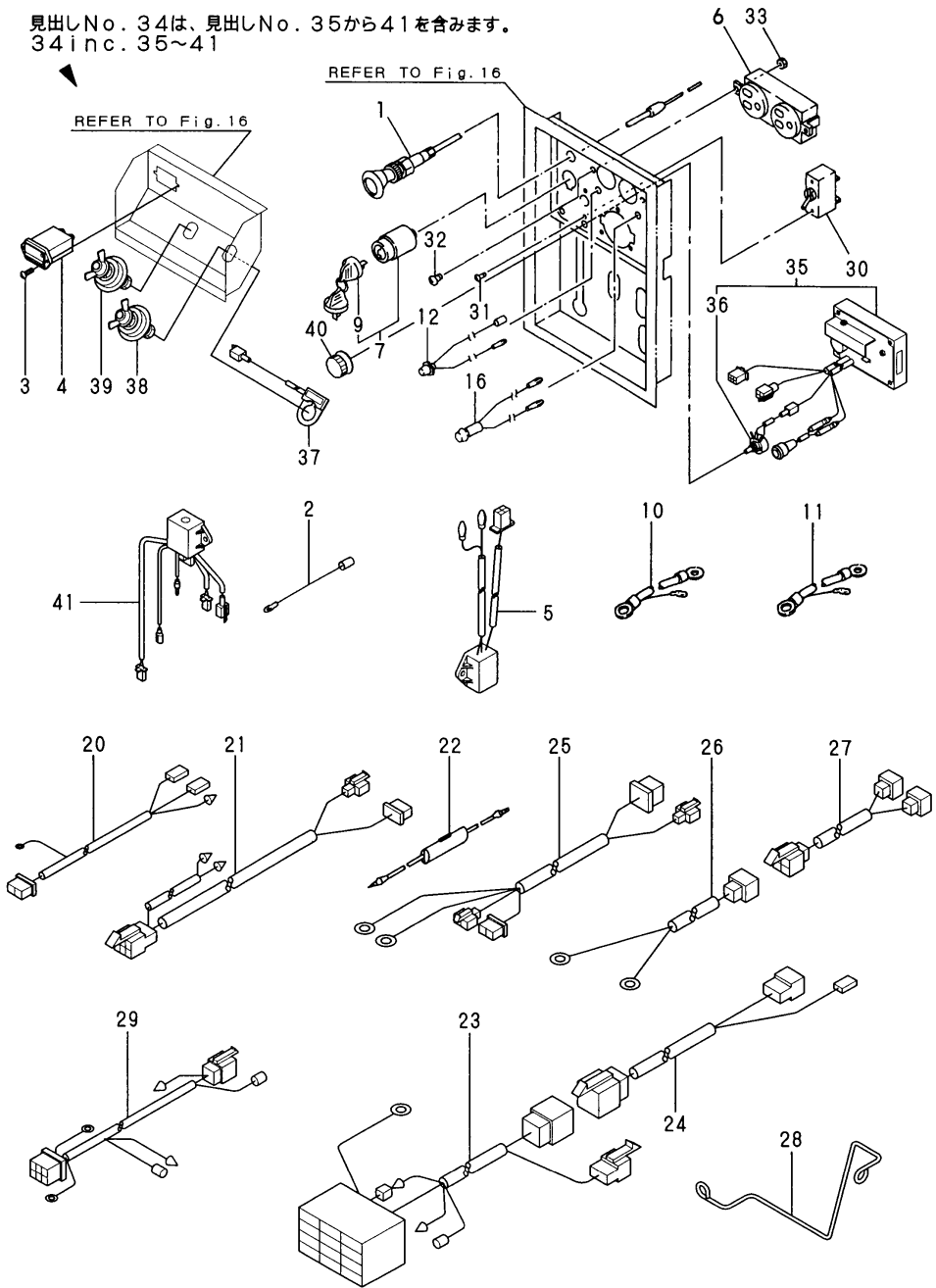

No.	Lev.	Parts No.	Description	Qty						I	R
				(A)	(B)	(C)	(D)	(E)	(F)		
1	1	183703-56900	WIRE ASSY, CHOKE		1						
2	1	160671-78200	WIRE, LEAD		1						
3	1	26557-030122	SCREW, M3X12				2				
4	1	183367-91070	METER, HOUR		1						
5	1	183135-91080	STOPPER		1						
6	1	183920-91320	SOCKET, 125VX2		1						
7	1	183920-91450	SWITCH ASSY, KEY				1				
9	2	183920-91280	KEY, STARTER				1				
10	1	183703-91720	CABLE ASSY, +				1				
11	1	183703-91730	CABLE ASSY, -				1				
12	1	183732-95500	ALERT ASSY				1				
16	1	183732-95510	LAMP ASSY, PILOT				1				
20	1	183703-95620	HARNESS, WIRE				1				
21	1	183703-95630	HARNESS ASSY, WIRE				1				
22	1	183131-95640	FUSE ASSY				1				
23	1	183703-95640	HARNESS ASSY, WIRE				1				
24	1	183703-95650	HARNESS ASSY, WIRE				1				
25	1	183703-95670	HARNESS, WIRE				1				
26	1	183703-95680	HARNESS ASSY, WIRE				1				
27	1	183703-95690	HARNESS ASSY, WIRE				1				
28	1	183703-95900	SUPPORT				1				
29	1	183703-95920	HARNESS, WIRE				1				
30	1	183000-96550	BREAKER, AC 25A				1				
31	1	26557-030062	SCREW, M3X 6				2				
32	1	26557-040062	SCREW, M4X 6				2				
33	1	26757-040002	NUT, LOCK M4				2				
34	1	183703-91050	PARTS ASSY, ELECTRIC				1				
35	2	183703-74500	REGULATOR, VOLTAGE				1				
36	3	183131-91712	RESISTOR ASSY				1				
37	2	183101-91171	SWITCH ASSY				1				
38	2	183101-91160	TERMINAL SET				1				
39	2	183101-91150	TERMINAL SET (-)				1				
40	2	183231-91690	KNOB				1				
41	2	183976-78850	TRANSFORMER, CURRENT				1				

Fig.20. CYLINDER BLOCK(COMPRESSOR)(YGC6SS-WCM)

(A)=YGC6SS-WCM  
 (B)=YGC10SS-WCM  
 (C)=

(D)=  
 (E)=  
 (F)=

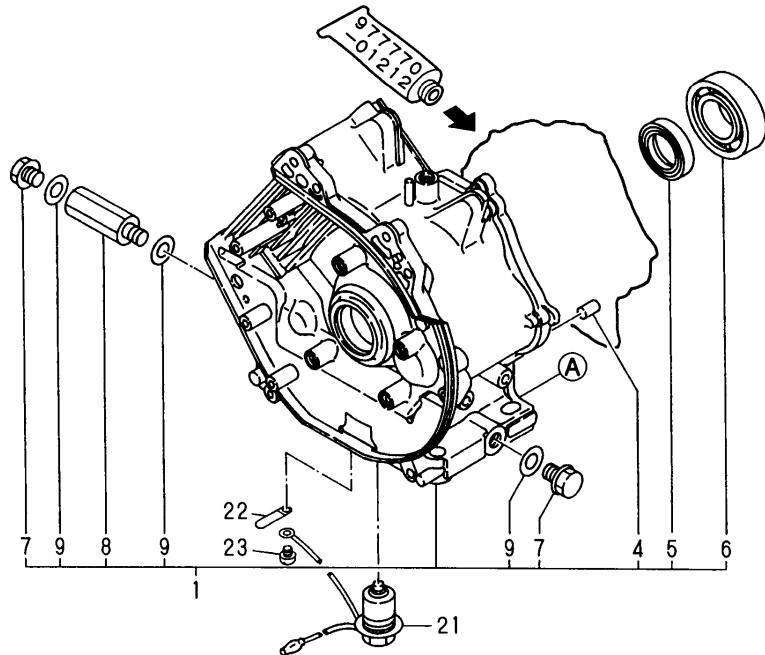
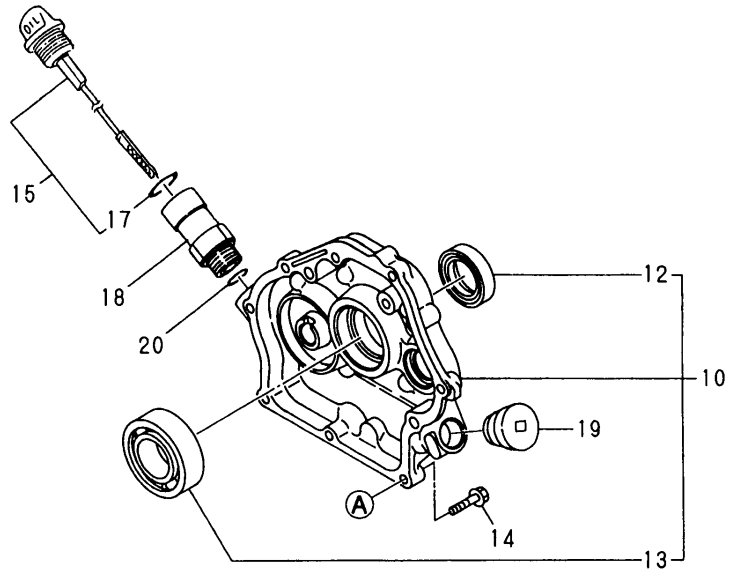

No.	Lev.	Parts No.	Description	Q'ty						I	R
				(A)	(B)	(C)	(D)	(E)	(F)		
1	1	783702-01640	BLOCK ASSY, CYLINDER	1							
4	2	114270-01600	PIN, M8X12	2							
5	2	160690-02220	SEAL, TC25416	1							
6	2	24101-062050	BEARING, BALL 6205C3	1							
7	2	160610-01690	PLUG, M12	2							
8	2	160802-01700	JOINT, DRAIN	1							
9	2	104200-59170	GASKET, 12	3							
10	1	783702-01511	COVER ASSY	1							
12	2	160690-02220	SEAL, TC25416	1							
13	2	24101-062050	BEARING, BALL 6205C3	1							
14	1	26476-060252	SCREW, TAPPING M6X25	8							
15	1	160698-01760	CAP ASSY	1							
17	2	24311-000180	O-RING, 1AP18.0	1							
18	1	160797-01851	JOINT	1							
19	1	160110-01870	PLUG, RUBBER	1							
20	1	24311-000180	O-RING, 1AP18.0	1							
21	1	160770-78820	SENSOR	1							
22	1	160260-78700	CLAMP	1							
23	1	26476-060142	SCREW, TAPPING M6X14	1							

Fig.21. CYLINDER BLOCK(COMPRESSOR)(YGC10SS-WCM)

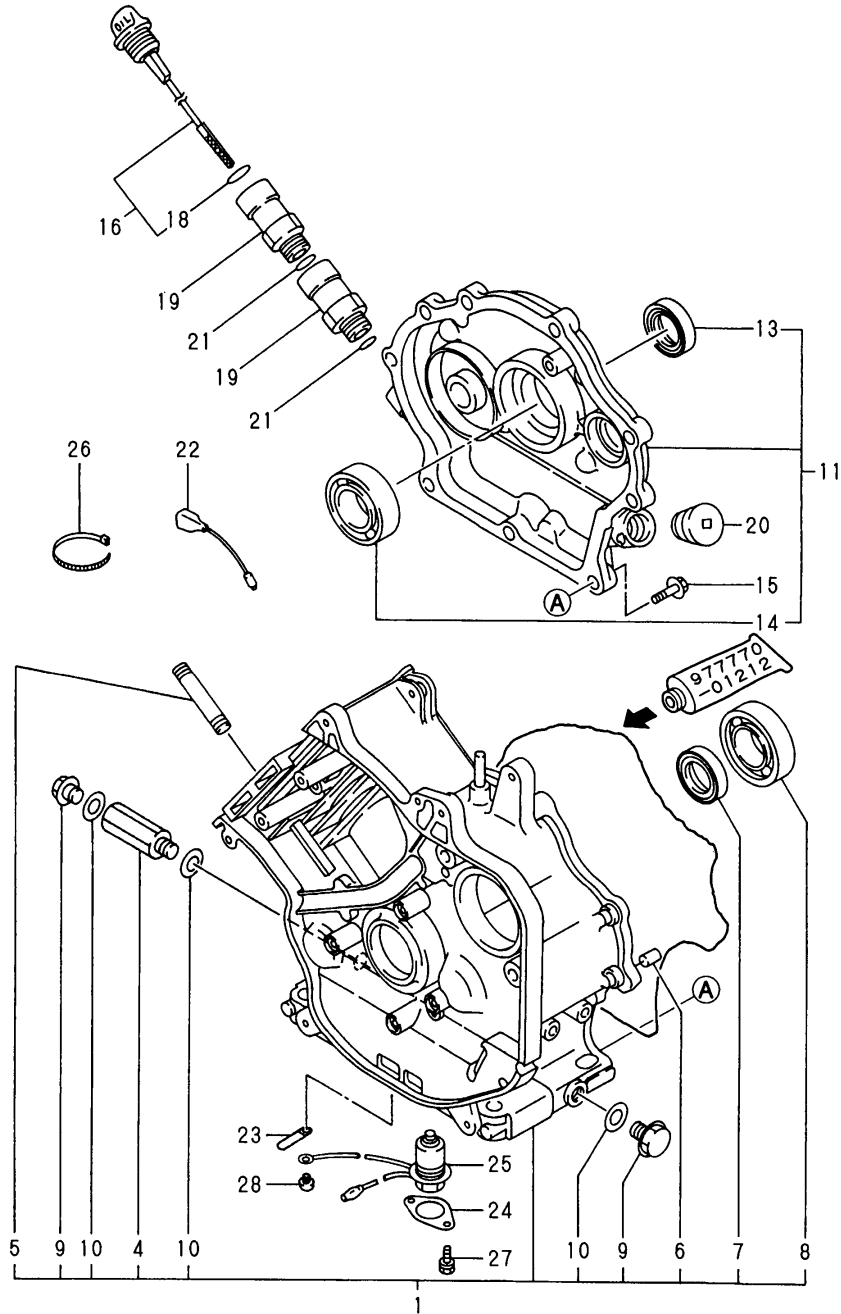

(A)=YGC6SS-WCM  
(B)=YGC10SS-WCM  
(C)=

(D)=  
(E)=  
(F)=

No.	Lev.	Parts No.	Description	Q'ty						I	R
				(A)	(B)	(C)	(D)	(E)	(F)		
1	1	783703-01640	BLOCK ASSY, CYLINDER		1						
4	2	183703-92700	JOINT, DRAIN		1						
5	2	26226-100902	STUD, M10X 90		4						
6	1	114270-01600	PIN, M8X12		2						
7	2	160110-02220	SEAL, OIL		1						
8	2	24101-062060	BEARING, BALL 6206C3		1						
9	2	160610-01690	PLUG, M12		2						
10	2	104200-59170	GASKET, 12		3						
11	1	783703-01510	COVER ASSY		1						
13	2	160110-02220	SEAL, OIL		1						
14	2	24101-062060	BEARING, BALL 6206C3		1						
15	1	26476-060252	SCREW, TAPPING M6X25		8						
16	1	160797-01760	CAP ASSY		1						
18	2	24311-000180	O-RING, 1AP18.0		1						
19	1	160797-01851	JOINT		2						
20	1	160110-01870	PLUG, RUBBER		1						
21	1	24311-000180	O-RING, 1AP18.0		2						
22	1	160975-78200	WIRE, LEAD		1						
23	1	160710-78710	CLAMP, CORD		1						
24	1	160797-78800	COVER		1						
25	1	160797-78810	SENSOR		1						
26	1	160370-78950	BAND, L=98		1						
27	1	114351-77550	SCREW, M4X6		2						
28	1	26476-060142	SCREW, TAPPING M6X14		1						

Fig.22. CYLINDER HEAD & AIR TANK(YGC6SS-WCM)

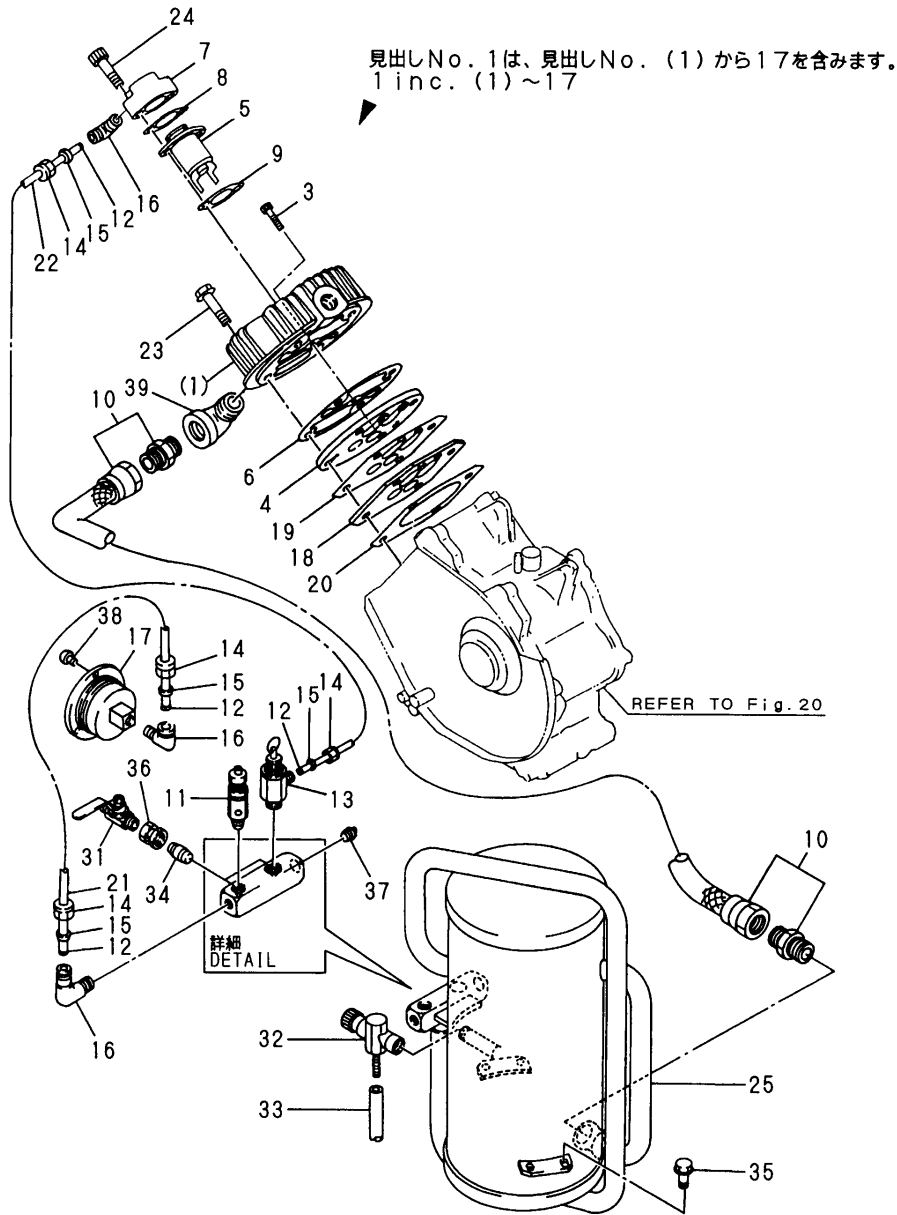

(A)=YGC6SS-WCM  
(B)=YGC10SS-WCM  
(C)=

(D)=  
(E)=  
(F)=

No.	Lev.	Parts No.	Description	Qty						I	R
				(A)	(B)	(C)	(D)	(E)	(F)		
1	1	183702-01002	COVER ASSY	1							
3	2	183702-93670	BOLT, HEAD M5X40	1							
4	2	183702-93511	VALVE SET	1							
5	2	183702-93520	PISTON SET	1							
6	2	183702-93531	GASKET	1							
7	2	183702-93540	CAP	1							
8	2	183702-93550	GASKET	1							
9	2	183702-93560	GASKET	1							
10	2	183702-93571	HOSE, FLEXIBLE	1							
11	2	183702-93830	VALVE, SAFETY	1							
12	2	183702-93650	SLEEVE	4							
13	2	183702-93850	VALVE, PILOT	1							
14	2	183702-93610	NUT, CAP 1/4	4							
15	2	183702-93620	BALL	4							
16	2	183702-93630	ELBOW, 1/8X1/4	3							
17	2	183702-93590	GAUGE	1							
18	1	183702-93050	SPACER	1							
19	1	183702-93060	GASKET, A	1							
20	1	183702-93070	GASKET, B	1							
21	1	183702-93700	HOSE, L=250	1							
22	1	183702-93710	HOSE, L=220	1							
23	1	26106-080382	BOLT, M8X 38 PLATED	4							
24	1	26450-080302	BOLT, M8X 30	2							
25	1	183703-94050	TANK ASSY, AIR	1							
31	1	183702-94252	VALVE	2							
32	1	183702-94270	VALVE, DRAIN	1							
33	1	183702-94280	HOSE, DRAIN	1							
34	1	183703-94400	NIPPLE, 1/4	2							
35	1	26106-060122	BOLT, M6X 12 PLATED	4							
36	1	23131-020000	SOCKET, R1/4	2							
37	1	23171-020000	PLUG, R1/4	1							
38	1	26557-040102	SCREW, M4X10	3							
39	1	23112-040000	ELBOW, R1/2	2							

Fig.23. CYLINDER HEAD & AIR TANK(YGC10SS-WCM)

(A)=YGC6SS-WCM  
(B)=YGC10SS-WCM  
(C)=

(D)=  
(E)=  
(F)=

見出しNo. 1は、見出しNo. (1) から22を含みます。  
1 inc. (1) ~ 22

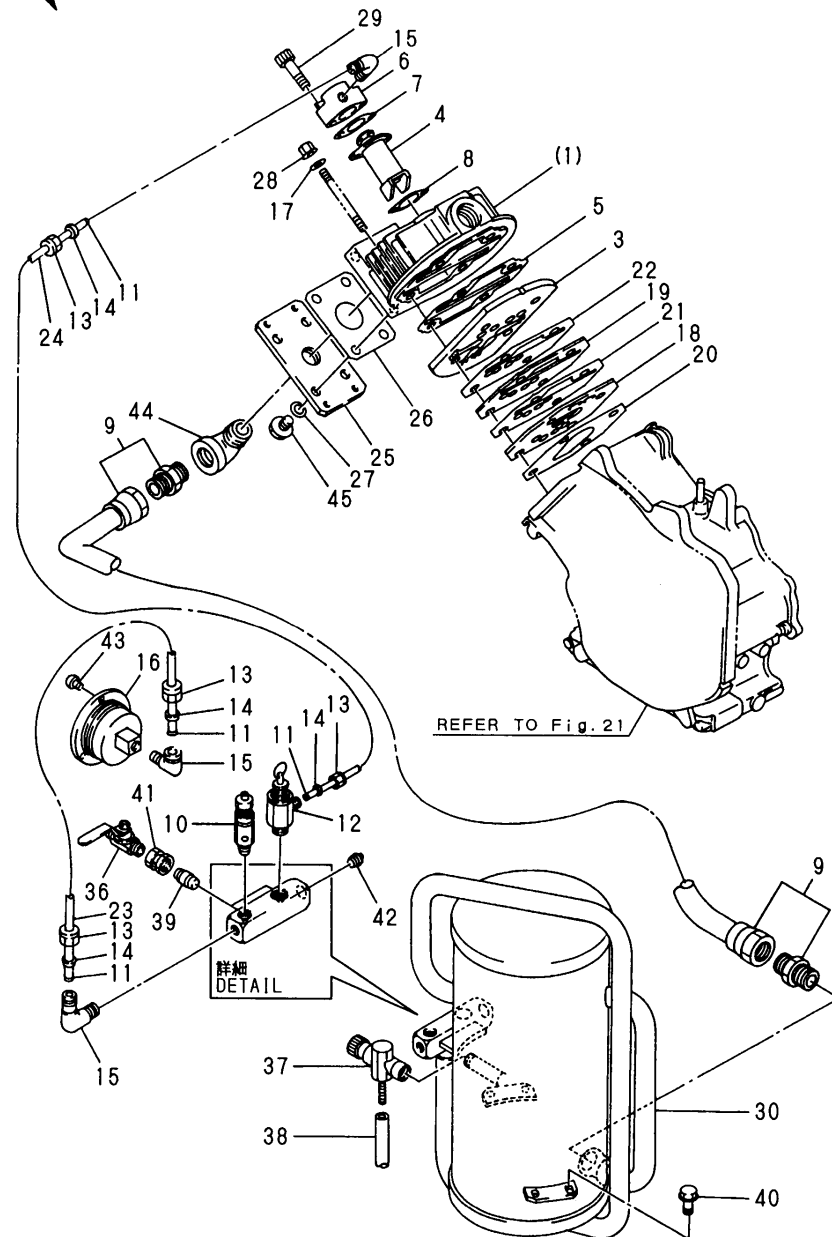

No.	Lev.	Parts No.	Description	Q'ty						I	R
				(A)	(B)	(C)	(D)	(E)	(F)		
1	1	183703-93590	COVER ASSY		1						
3	2	183703-93510	VALVE SET		1						
4	2	183703-93520	PISTON SET		1						
5	2	183703-93530	GASKET		1						
6	2	183702-93540	CAP		1						
7	2	183702-93550	GASKET		1						
8	2	183702-93560	GASKET		1						
9	2	183703-93570	HOSE, L400		1						
10	2	183702-93830	VALVE, SAFETY		1						
11	2	183702-93650	SLEEVE		4						
12	2	183702-93850	VALVE, PILOT		1						
13	2	183702-93610	NUT, CAP 1/4		4						
14	2	183702-93620	BALL		4						
15	2	183702-93630	ELBOW, 1/8X1/4		4						
16	2	183702-93590	GAUGE		1						
17	1	105425-01250	WASHER		4						
18	1	183703-93050	SPACER		1						
19	1	183703-93090	SPACER		1						
20	1	183703-93110	GASKET, A		1						
21	1	183703-93130	GASKET, B		1						
22	1	183703-93150	GASKET		1						
23	1	183703-93700	HOSE		1						
24	1	183703-93710	HOSE		1						
25	1	183703-93760	FLANGE		1						
26	1	183703-93770	GASKET		1						
27	1	22217-100000	WASHER, SPRING 10		4						
28	1	26366-100002	NUT, M10		4						
29	1	26450-080302	BOLT, M8X 30		2						
30	1	183703-94050	TANK ASSY, AIR		1						
36	1	183702-94252	VALVE		2						
37	1	183702-94270	VALVE, DRAIN		1						
38	1	183702-94280	HOSE, DRAIN		1						
39	1	183703-94400	NIPPLE, 1/4		2						
40	1	26106-060122	BOLT, M6X 12 PLATED		4						
41	1	23131-020000	SOCKET, R1/4		2						
42	1	23171-020000	PLUG, R1/4		1						
43	1	26557-040102	SCREW, M4X10		3						
44	1	23112-040000	ELBOW, R1/2		2						
45	1	26106-080252	BOLT, M8X 25 PLATED		4						

Fig.24. AIR CLEANER & DUCT(YGC6SS-WCM)

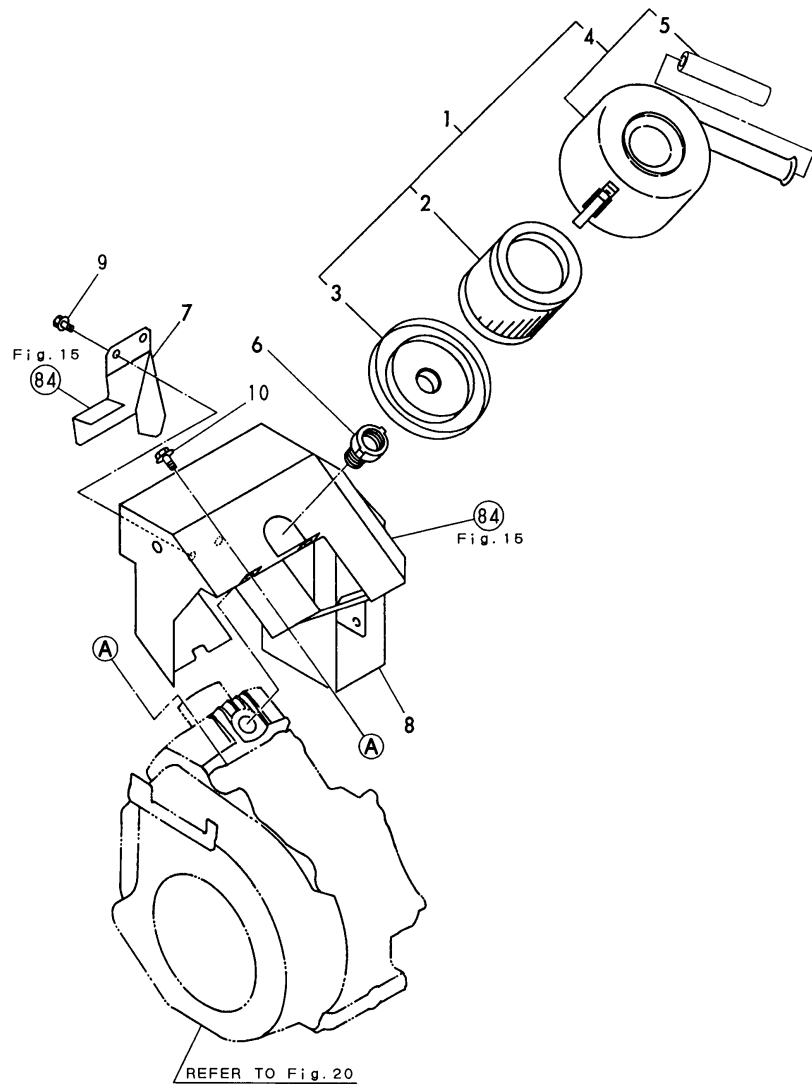

(A)=YGC6SS-WCM  
(B)=YGC10SS-WCM  
(C)=

(D)=  
(E)=  
(F)=

No.	Lev.	Parts No.	Description	Q'ty						I	R
				(A)	(B)	(C)	(D)	(E)	(F)		
1	1	183702-93200	CLEANER, AIR	1							
2	2	183702-93230	ELEMENT	1							
3	2	183702-93240	PLATE	1							
4	2	183702-93250	BODY	1							
5	3	183702-93220	PIPE	1							
6	1	183702-93210	SOCKET	1							
7	1	183702-93750	COVER	1							
8	1	183702-95200	DUCT, COMPRESSER	1							
9	1	26106-060102	BOLT, M6X 10 PLATED	2							
10	1	26476-060142	SCREW, TAPPING M6X14	2							

注) 図番を○で囲んでいるものは、内側に付けるスポンジ又はグラスウールを示しています。  
NOTE) THE ENCIRCLED DRAWING NUMBERS INDICATES THE PARTS LINED WITH RUBBER SPONGE OR GLASS WOOL.

Remarks  
THE ENCIRCLED DRAWING NUMBER(REF.NO.)  
84)IS SEE FIG15.



Fig.25. AIR CLEANER & DUCT(YGC10SS-WCM)

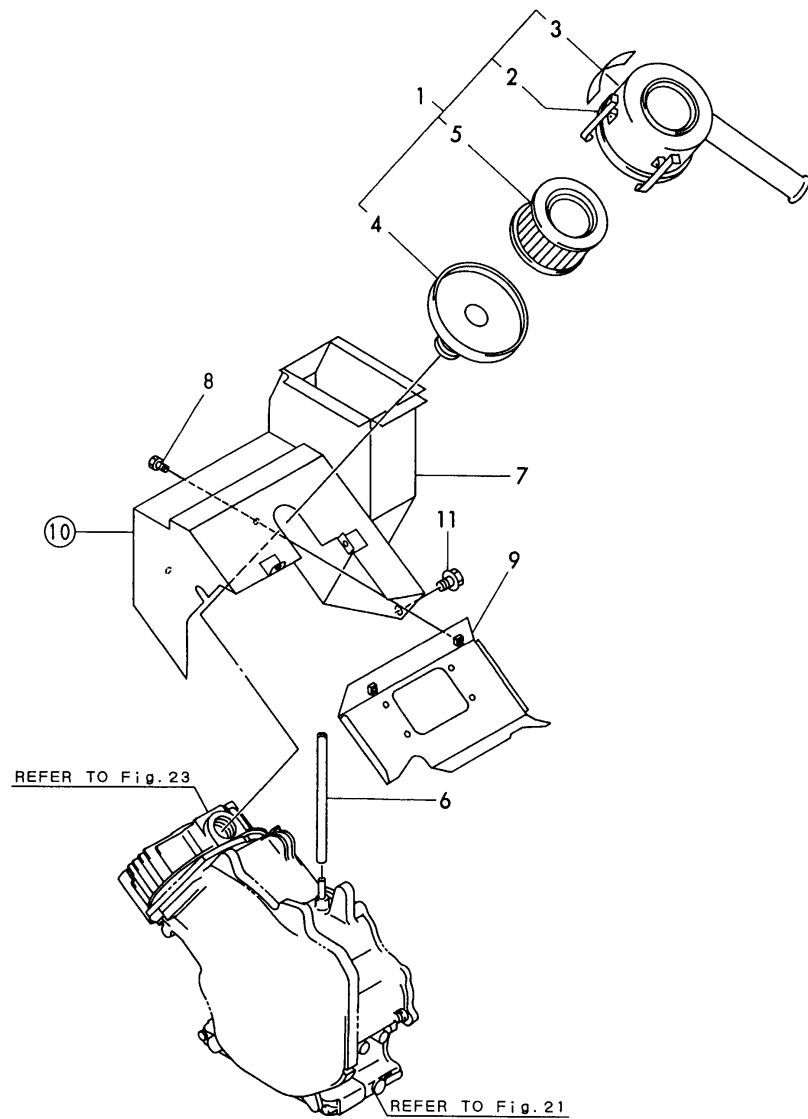

(A)=YGC6SS-WCM  
(B)=YGC10SS-WCM  
(C)=

(D)=  
(E)=  
(F)=

No.	Lev.	Parts No.	Description	Q'ty						I	R
				(A)	(B)	(C)	(D)	(E)	(F)		
1	1	183703-93200	CLEANER, AIR		1						
2	2	183703-93210	BODY		1						
3	2	183703-93240	LABEL		1						
4	2	183703-93220	PLATE		1						
5	2	183703-93230	ELEMENT		1						
6	1	183210-55140	HOSE, BREATHER		1						
7	1	183703-95201	DUCT, COMPRESSER		1						
8	1	26476-060142	SCREW, TAPPING M6X14		2						
9	1	183703-95300	DUCT, COMPRESSER		1						
10	1	183703-95601	ISOLATOR ASSY		1						
11	1	26106-080142	BOLT, M8X 14 PLATED		2						

注) 図番を○で囲んでいるものは、内側に付けるスポンジ又はグラスウールを示しています。  
NOTE) THE ENCIRCLED DRAWING NUMBERS INDICATES THE PARTS LINED WITH RUBBER SPONGE OR GLASS WOOL.

Fig.26. PISTON & CRANKSHAFT(COMPRESSOR)

(A)=YGC6SS-WCM  
(B)=YGC10SS-WCM  
(C)=

(D)=  
(E)=  
(F)=

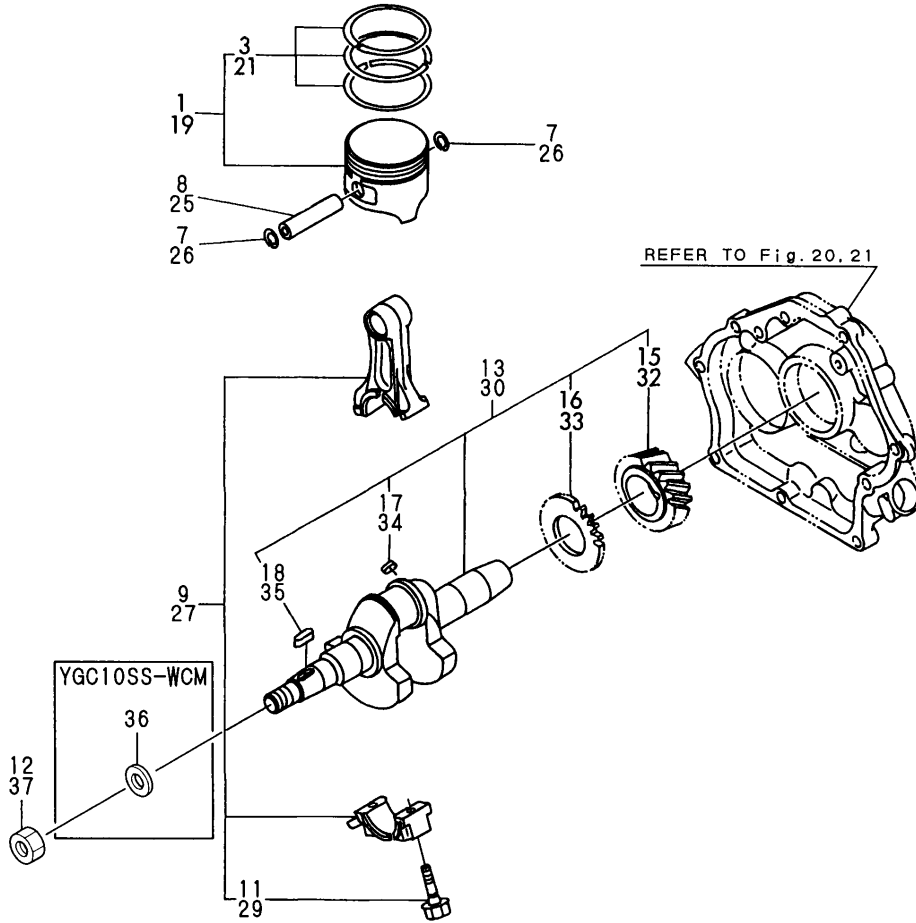

No.	Lev.	Parts No.	Description	Q'ty						I	R
				(A)	(B)	(C)	(D)	(E)	(F)		
1	1	783702-22720	PISTON ASSY	1							
3	2	783702-22500	RING SET, PISTON	1							
7	1	22252-000160	RING, 16	2							
8	1	160690-22300	PIN, PISTON	1							
9	1	760690-23700	ROD ASSY, CONNECTING	1							
11	2	26106-060302	BOLT, M6X 30 PLATED	2							
12	1	160610-04910	NUT, FLYWHEEL M14	1							
13	1	760699-21720	CRANKSHAFT ASSY	1							
15	2	160690-21201	GEAR, CRANKSHAFT	1							
16	2	160590-21210	GEAR, IDLE	1							
17	2	22512-040120	KEY, 4X 12	1							
18	2	22512-040160	KEY, 4X 16	1							
19	1	783703-22721	PISTON ASSY		1						
21	2	783703-22501	RING SET, 0.25 OS		1						
25	1	160890-22300	PIN, PISTON		1						
26	1	22252-000190	RING, 19		2						
27	1	760890-23700	ROD ASSY, CONNECTING		1						
29	2	160810-23201	BOLT, CONNECTING ROD		2						
30	1	760998-21710	CRANKSHAFT ASSY		1						
32	2	160890-21200	GEAR, CRANKSHAFT		1						
33	2	160890-21220	GEAR, BALANCER		1						
34	2	22512-040160	KEY, 4X 16		1						
35	2	22512-040300	KEY, 4X 30		1						
36	1	22137-160000	WASHER, 16		1						
37	1	26737-160002	NUT, M16		1						

Fig.27. COOLING FAN & BREATHER

(A)=YGC6SS-WCM  
 (B)=YGC10SS-WCM  
 (C)=

(D)=  
 (E)=  
 (F)=

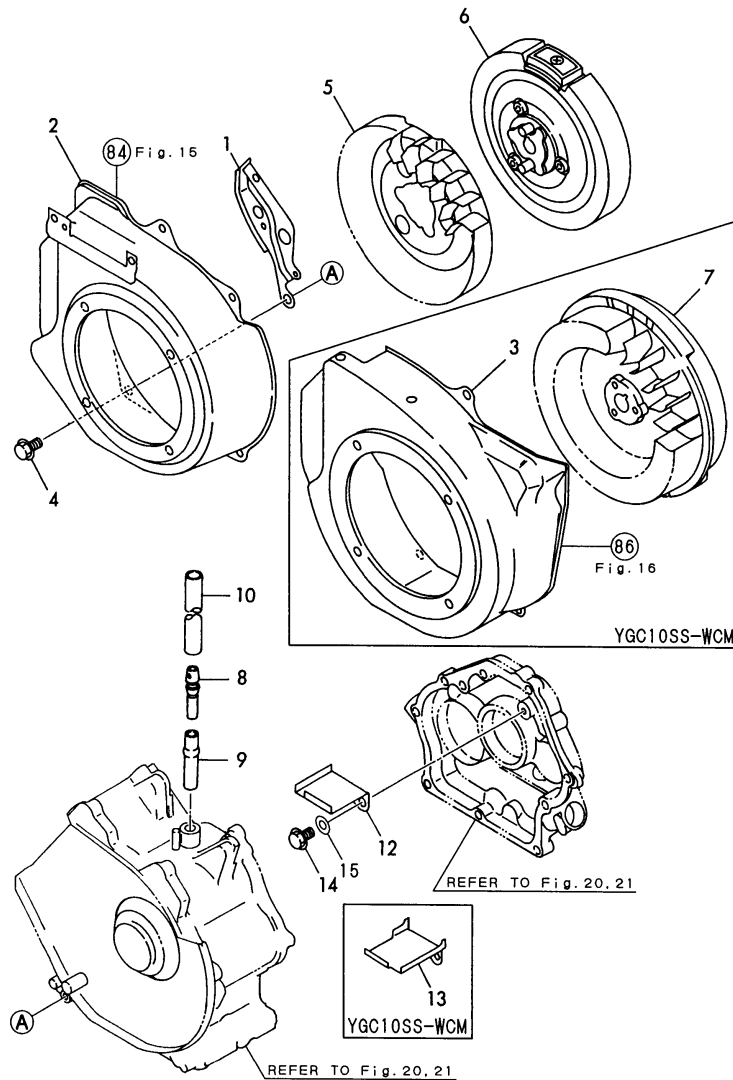

No.	Lev.	Parts No.	Description	Q'ty						I	R
				(A)	(B)	(C)	(D)	(E)	(F)		
1	1	160690-45211	COVER	1	1						
2	1	183702-95150	CASE, COOLING FAN	1							
3	1	183703-95150	CASE, COOLING FAN		1						
4	1	26476-060142	SCREW, TAPPING M6X14	5	5						
5	1	160694-45010	FAN, COOLING	1							
6	1	160694-78500	ROTOR	1							
7	1	160890-78550	ROTOR		1						
8	1	160690-03050	BREATHER	1	1						
9	1	183702-92150	MOUNT	1	1						
10	1	183702-92160	HOSE, BREATHER	1	1						
12	1	183702-92190	PLATE, BAFFLE	1							
13	1	183703-92190	PLATE, BAFFLE			1					
14	1	26476-060142	SCREW, TAPPING M6X14	1	1						
15	1	160120-76940	WASHER	1	1						

注) 図番を○で囲んでいるものは、内側に付けるスポンジ又はグラスウールを示しています。  
 NOTE) THE ENCIRCLED DAWING NUMBERS INDICATES THE PARTS LINED WITH RUBBER SPONGE OR GLASS WOOL.

Remarks  
 THE ENCIRCLED DAWING NUMBER  
 (REF NO.84)IS SEE FIG.15.  
 THE ENCIRCLED DAWING NUMBER  
 (REF NO.86)IS SEE FIG.16.

Fig.28. TENSION CLUTCH(YGC6SS-WCM)

(A)=YGC6SS-WCM  
 (B)=YGC10SS-WCM  
 (C)=

(D)=  
 (E)=  
 (F)=

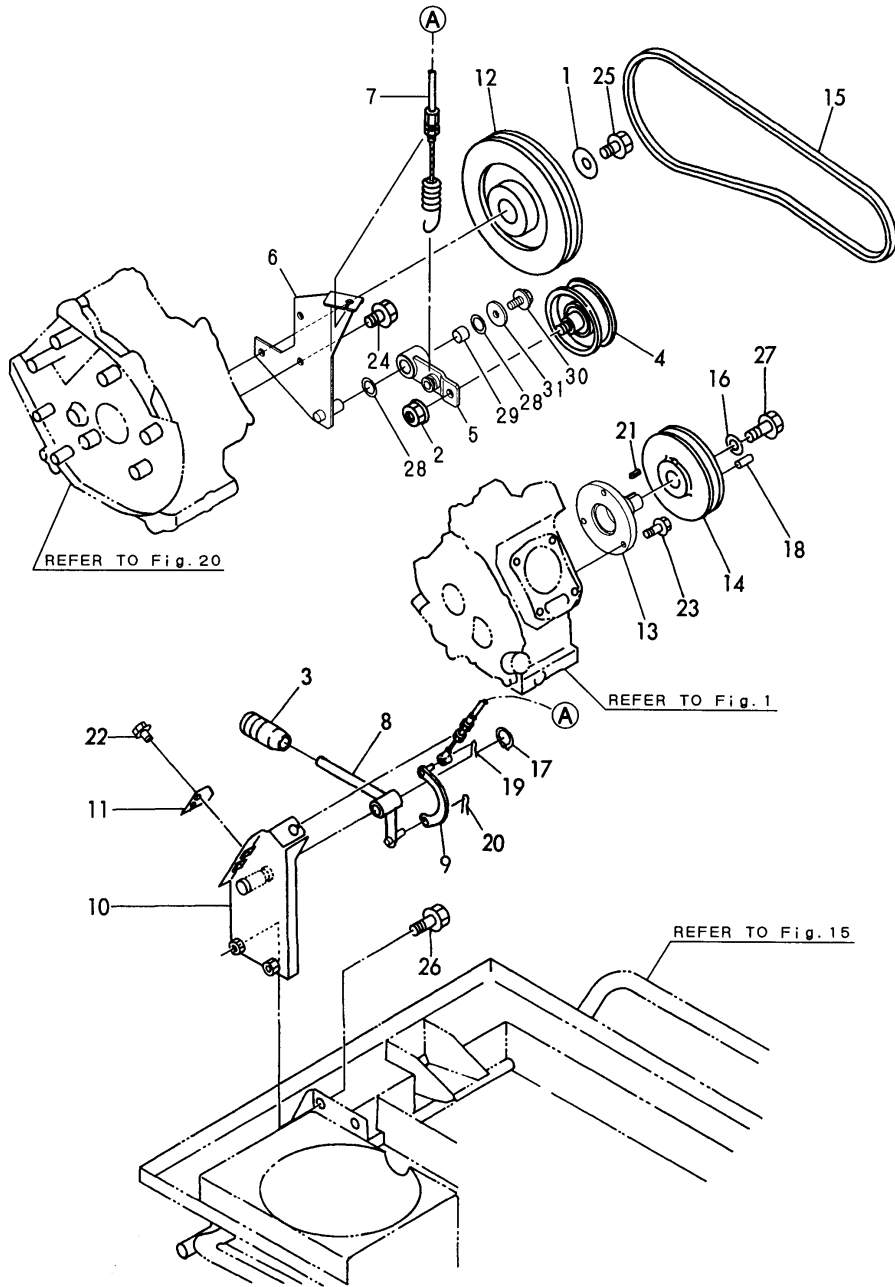

No.	Lev.	Parts No.	Description	Q'ty						I	R
				(A)	(B)	(C)	(D)	(E)	(F)		
1	1	160310-14550	WASHER	1							
2	1	194990-22150	NUT, M10	1							
3	1	1E6570-65750	GRIP,CONT.LEVER BLK.	1							
4	1	183702-81100	PULLEY, TENSION	1							
5	1	183702-81111	ARM	1							
6	1	183702-81121	SUPPORT	1							
7	1	183702-81131	WIRE ASSY, CLUTCH	1							
8	1	183702-81200	LEVER	1							
9	1	183702-81210	LINK	1							
10	1	183702-81220	SUPPORT	1							
11	1	183702-81230	STOPPER	1							
12	1	183702-81300	PULLEY	1							
13	1	183702-81430	SHAFT, PTO	1							
14	1	183702-81410	PULLEY	1							
15	1	183702-81451	V-BELT	1							
16	1	22117-100000	WASHER, 10	1							
17	1	22242-000120	RING, 12	1							
18	1	22312-060250	PIN, PARALLEL M6X25	1							
19	1	22360-060000	PIN, SNAP 6	1							
20	1	22372-080000	PIN, SNAP 8	1							
21	1	22512-040160	KEY, 4X 16	1							
22	1	26106-060122	BOLT, M6X 12 PLATED	2							
23	1	26013-060222	BOLT, M6X 22	3							
24	1	26106-080142	BOLT, M8X 14 PLATED	3							
25	1	26106-080142	BOLT, M8X 14 PLATED	1							
26	1	26106-080202	BOLT, M8X 20 PLATED	2							
27	1	26106-100202	BOLT, M10X 20 PLATED	1							
28	1	175020-24201	WASHER	2							
29	1	24550-014120	BUSH, 14X12	1							
30	1	26106-060122	BOLT, M6X 12 PLATED	1							
31	1	105340-66840	WASHER	1							

Fig.29. TENSION CLUTCH(YGC10SS-WCM)

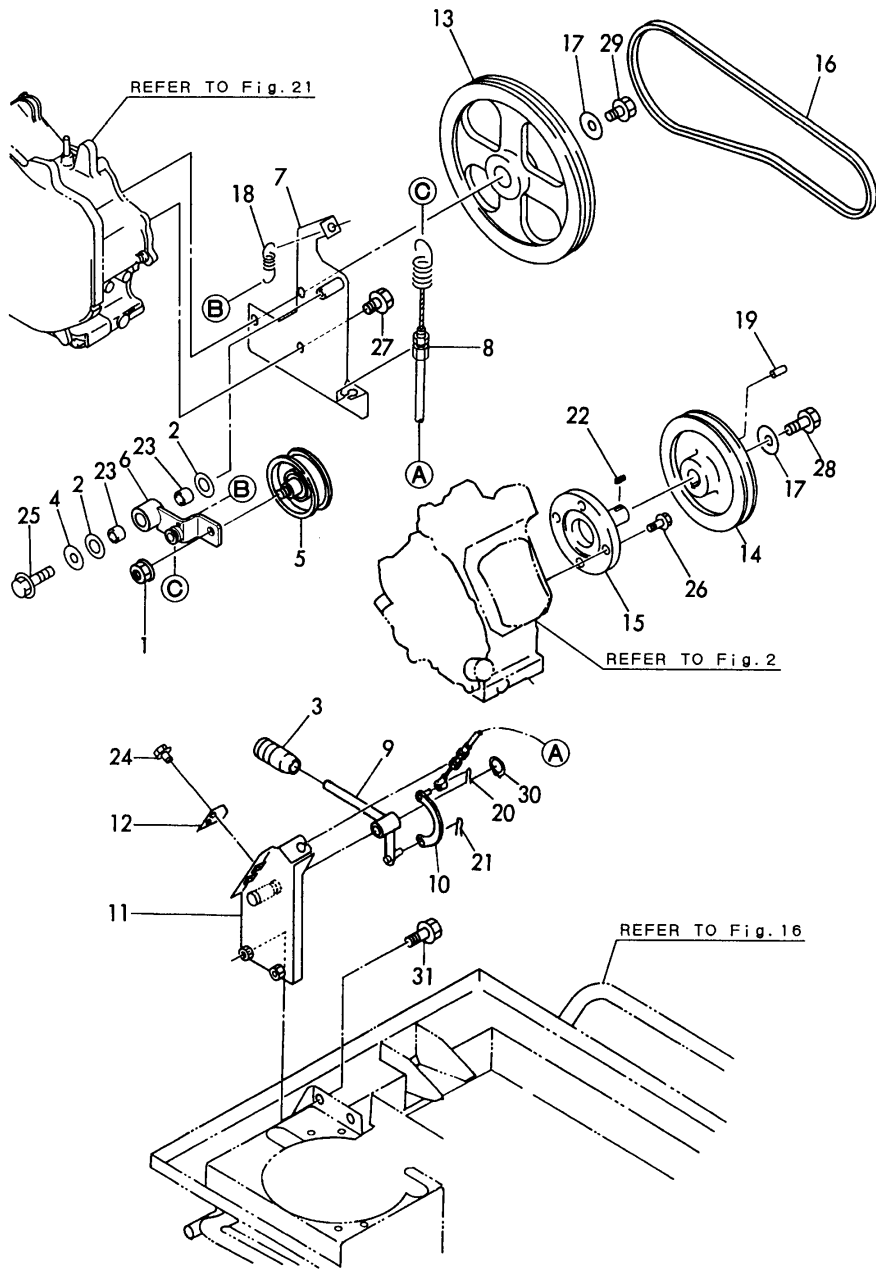

(A)=YGC6SS-WCM  
(B)=YGC10SS-WCM  
(C)=

(D)=  
(E)=  
(F)=

No.	Lev.	Parts No.	Description	Q'ty						I	R
				(A)	(B)	(C)	(D)	(E)	(F)		
1	1	194990-22150	NUT, M10		1						
2	1	175020-24201	WASHER		2						
3	1	1E6570-65750	GRIP,CONT.LEVER BLK.		1						
4	1	105340-66840	WASHER		1						
5	1	183702-81100	PULLEY, TENSION		1						
6	1	183703-81111	ARM		1						
7	1	183703-81121	SUPPORT		1						
8	1	183703-81131	WIRE ASSY, CLUTCH		1						
9	1	183702-81200	LEVER		1						
10	1	183702-81210	LINK		1						
11	1	183702-81220	SUPPORT		1						
12	1	183702-81230	STOPPER		1						
13	1	183703-81300	PULLEY		1						
14	1	183703-81410	PULLEY		1						
15	1	183703-81450	SHAFT, PTO		1						
16	1	183703-81471	V-BELT		1						
17	1	183703-81500	WASHER		2						
18	1	183703-81990	SPRING, RETURN		1						
19	1	22312-060250	PIN, PARALLEL M6X25		1						
20	1	22360-060000	PIN, SNAP 6		1						
21	1	22372-080000	PIN, SNAP 8		1						
22	1	22512-040160	KEY, 4X 16		1						
23	1	24550-014120	BUSH, 14X12		2						
24	1	26106-060122	BOLT, M6X 12 PLATED		2						
25	1	26106-060122	BOLT, M6X 12 PLATED		1						
26	1	26106-080252	BOLT, M8X 25 PLATED		4						
27	1	26106-080142	BOLT, M8X 14 PLATED		3						
28	1	26106-100202	BOLT, M10X 20 PLATED		1						
29	1	26106-100252	BOLT, M10X 25 PLATED		1						
30	1	22242-000120	RING, 12		1						
31	1	26106-080202	BOLT, M8X 20 PLATED		2						

## Parts No. Index

Parts No.	Fig. No.	Ref. No.
101147-12550	16	110
101158-11180	3	9
104200-59170	1	8
	2	6
	20	9
	21	10
105250-07330	14	22
105250-07340	14	30
105340-66840	28	31
	29	4
105425-01250	4	24
	23	17
106990-44660	7	20
	16	109
114250-14400	6	11
114270-01600	1	4
	2	4
	20	4
	21	6
114351-77550	2	24
	21	27
114362-77011	13	1
114371-77160	13	7
114371-77170	13	13
114371-79040	13	8
114371-79050	13	9
114371-79060	13	10
114371-79070	13	17
114381-77110	13	2
114381-77130	13	5
114381-77140	13	6
114381-77150	13	12
114770-61600	10	49
124060-77680	7	23
128620-18210	17	18
129470-49040	5	2
160110-01870	1	22
	2	19
	20	19
	21	20
160110-02220	2	7
		11
	21	7
		13
160110-92610	14	41
160110-92710	14	43
160120-56670	8	3
	9	3
160120-76940	10	9
	27	15

Parts No.	Fig. No.	Ref. No.
160120-92700	14	42
160210-56610	9	16
160211-56950	9	29
160260-76620	12	35
160260-78700	1	19
	18	4
	20	22
160310-14550	28	1
160330-56740	8	6
160370-78950	21	26
160490-14200	6	10
160510-14550	15	72
160520-07272	14	26
160520-07370	14	28
160520-66291	10	28
160590-21210	6	16
	26	16
160590-56800	8	28
160591-01750	1	16
160591-01760	1	15
160593-56530	8	5
160594-56590	8	17
160594-56650	8	15
160594-56810	8	13
160610-01690	1	7
	2	5
	20	7
	21	9
160610-03050	4	20
160610-04201	3	1
160610-04570	5	1
160610-04910	6	12
	26	12
160610-55100	7	6
160610-55460	15	117
160610-55470	15	118
160610-56150	5	3
	8	33
160610-56610	8	18
160610-56611	8	22
160610-56630	8	10
	9	10
160610-56660	8	21
160610-56900	8	31
160640-56850	8	25
	9	24
160641-76530	11	41
160641-76550	12	29
160641-76570	11	44
	12	32

Parts No.	Fig. No.	Ref. No.
160664-55300	7	10
160667-56750	8	26
	9	25
160670-66350	10	33
160671-78200	13	20
	18	3
	19	2
160690-02220	1	5
		13
	20	5
		12
160690-03050	3	20
	27	8
160690-07320	14	9
160690-11010	3	2
160690-11130	3	6
160690-11140	3	7
160690-11150	3	8
160690-11220	3	11
	4	12
160690-11221	3	11 -1
	4	12 -1
160690-11271	3	12
	4	13
160690-11280	3	13
	4	14
160690-11290	3	14
160690-11300	3	16
160690-11310	3	17
160690-13200	5	7
160690-14571	6	8
160690-21201	6	15
	26	15
160690-22300	6	25
	26	8
160690-45200	11	5
160690-45211	11	2
	27	1
160690-56160	8	34
160690-61301	10	2
160690-61311	10	3
160690-61450	10	4
160690-61600	10	5
160690-66180	10	39
160690-66200	10	42
160690-66210	10	47
160690-78230	11	23
	12	43
160690-78532	11	22
160692-07250	14	8

Parts No.	Fig. No.	Ref. No.
160692-55421	7	18
160692-56560	8	30
160692-56710	8	7
	9	7
160692-56770	8	29
160692-56800	8	14
160692-66051	10	16
160693-56570	8	20
160693-59350	7	21
160694-45010	27	5
160694-78500	27	6
160697-12560	5	15
160697-12570	5	16
160697-14050	6	1
160697-45900	11	7
160697-56620	8	11
160697-66010	10	12
160697-66100	10	14
160697-66110	10	21
160697-66121	10	23
160697-76510	11	39
	12	27
160697-76520	11	40
160697-76550	11	43
	12	31
160697-76570	11	45
	12	33
160697-76580	11	50
160697-76630	11	46
	12	36
160698-01760	20	15
160698-56550	8	12
160698-56820	8	2
160699-01331	3	22
160699-07200	14	24
160699-11200	3	10
160699-22010	6	19
160699-45010	11	29
160699-56050	8	1
160699-78060	11	21
160699-78520	11	24
160700-78040	11	33
	12	53
160700-78050	11	34
	12	54
160700-78720	11	35
	12	55
160702-56720	8	27
	9	26
160710-55301	7	11

## Parts No. Index

Parts No.	Fig. No.	Ref. No.
160710-55360	7	14
160710-55370	7	15
160710-55381	7	16
160710-55390	7	17
160710-78710	2	25
	12	47
	21	23
160720-55530	12	13
160730-56640	8	19
160730-56880	8	35
	9	35
160730-59370	7	26
160769-59370	7	27
160770-78820	1	20
	20	21
160770-78830	18	5
160790-56571	9	30
160790-56610	9	27
160792-56670	9	9
160792-59360	7	22
160793-78010	11	32
160794-78150	12	46
160797-01760	2	15
	21	16
160797-01851	1	23
	2	18
	20	18
	21	19
160797-45230	11	6
	12	7
160797-66200	10	15
160797-66210	10	22
160797-66221	10	24
160797-66310	10	31
160797-66320	10	32
160797-76520	12	28
160797-76580	12	34
160797-78522	12	42
160797-78800	2	21
	21	24
160797-78810	2	22
	21	25
160798-78560	11	25
160802-01700	1	9
	20	8
160802-78270	5	4
160810-03180	3	21
160810-11180	4	10
160810-23201	6	59
	26	29

Parts No.	Fig. No.	Ref. No.
160810-56580	8	16
	9	14
160820-03180	4	1
160890-01210	4	21
160890-11011	4	2
160890-11100	4	7
160890-11101	4	7 -1
160890-11110	4	8
160890-11111	4	8 -1
160890-11120	4	9
160890-11180	4	10 -1
160890-11190	4	10 -2
160890-11201	4	11
160890-11270	4	13 -1
160890-11290	4	15
160890-11300	4	17
160890-11310	4	18
160890-13210	5	27
160890-14200	6	40
160890-14400	6	39
160890-14560	6	37
160890-21200	6	43
	26	32
160890-21220	6	44
	26	33
160890-22300	6	55
	26	25
160890-45200	12	2
160890-56160	9	34
160890-56620	9	11
160890-66050	10	11
160890-66190	10	43
160890-76540	11	42
	12	30
160890-78550	27	7
160891-56530	9	15
160897-45130	12	1
160897-45920	11	8
	12	8
160897-45930	11	9
160897-66010	10	13
160900-76620	11	49
160903-56670	8	4
	9	4
160910-56150	5	23
	9	33
160940-78701	11	26
	12	57
160975-78200	21	22
160992-56520	9	2

Parts No.	Fig. No.	Ref. No.
160994-14051	6	30
160998-01200	4	22
160998-01330	4	25
160998-01950	16	104
160998-01960	16	105
160998-11200	4	11 -1
160998-12560	5	17
160998-12710	5	18
160998-12720	5	19
160998-12730	5	20
160998-12740	5	21
160998-12910	5	22
160998-22020	6	49
160998-45210	12	3
160998-56040	9	1
160998-56610	9	12
160998-56620	9	5
160998-56630	9	6
160998-56640	9	13
160998-56650	9	17
160998-56660	9	18
160998-56670	9	19
160998-56680	9	20
160998-56690	9	21
160998-56700	9	28
160998-56710	9	31
160998-56720	9	32
160998-66200	10	46
160998-76590	12	37
160998-78010	12	52
160998-78590	12	44
170001-07230	14	23
175020-24201	28	28
	29	2
175211-66100	18	2
181230-56380	8	8
	9	8
	9	32
183000-96550	18	29
	19	30
183100-74310	17	34
183100-74320	17	12
	25	
183100-74380	17	10
	26	
183100-74390	17	11
	27	
183100-74490	17	9
	31	
183101-07250	14	7

Parts No.	Fig. No.	Ref. No.
183101-91150	18	38
	19	39
183101-91160	18	37
	19	38
183101-91171	18	36
	19	37
183130-95760	18	27
183131-07360	14	11
183131-07410	14	32
183131-07450	14	34
183131-07600	14	35
183131-08300-1	15	120
183131-08310	15	119
183131-08910	15	68
	16	75
183131-08920	15	71
	16	76
183131-55050	7	5
183131-55060	7	3
183131-79550	16	113
183131-79601	16	116
183131-91712	18	35
	19	36
183131-95640	19	22
183135-79550	16	114
183135-91080	19	5
183135-91720	18	9
183135-91730	18	10
183135-95630	18	19
183210-55140	25	6
183211-07580	14	36
183231-74051	17	21
183231-74201	17	22
183231-74280	17	4
	23	
183231-74291	17	24
183231-74350	17	35
183231-74460	17	28
183231-74470	17	29
183231-74480	17	30
183231-91690	18	39
	19	40
183232-77520	11	62
	16	111
183250-08220	15	53
	16	62
183250-74271	17	5
	32	
183250-74272	17	5 -1
	32	-1

## Parts No. Index

Parts No.	Fig. No.	Ref. No.
183266-08360	15	54
183332-07420	14	21
183366-55210	7	24
183367-91070	19	4
183614-07700	14	31
183614-07710	14	37
183614-07720	14	38
183614-07730	14	39
183614-07740	14	40
183614-07750	14	29
183621-55150	7	8
183632-07600	14	6
183632-55050	15	75
	16	79
183671-08160	16	60
183701-07900	14	33
183701-08570	15	63
183702-01002	22	1
183702-07100	14	2
183702-07110	14	3
183702-07120	14	4
183702-07130	14	5
183702-07350	14	10
183702-07400	14	12
183702-07410	14	13
183702-07420	14	14
183702-07440	14	1
183702-07460	14	17
183702-08071-1	15	28
183702-08111	15	35
183702-08120-1	15	37
183702-08130-1	15	41
183702-08150-1	15	49
183702-08160-1	15	52
183702-08170-1	15	45
183702-08180	15	33
183702-08190	15	34
183702-08301-1	15	1
183702-08311-1	15	15
183702-08321-1	15	29
183702-08331-1	15	32
183702-08470	15	109
183702-08480	15	110
183702-08550-1	15	56
183702-08580	15	62
183702-08910	15	115
183702-08930	15	113
183702-12550	5	12
183702-12610	5	13
183702-12620	5	14

Parts No.	Fig. No.	Ref. No.
183702-13520	5	8
183702-13700	5	9
183702-45011	11	1
183702-45050	11	12
183702-45060	11	13
183702-45070	11	14
183702-45150	11	15
183702-74050	17	1
183702-74150	17	14
183702-74200	17	2
183702-74290	17	3
183702-74350	17	13
183702-74460	17	6
183702-74470	17	7
183702-74480	17	8
183702-74500	18	34
183702-76050	11	37
183702-76500	11	38
183702-76590	11	47
183702-76601	11	60
183702-76610	11	61
183702-76910	11	17
183702-81100	28	4
	29	5
183702-81111	28	5
183702-81121	28	6
183702-81131	28	7
183702-81200	28	8
	29	9
183702-81210	28	9
	29	10
183702-81220	28	10
	29	11
183702-81230	28	11
	29	12
183702-81300	28	12
183702-81410	28	14
183702-81430	28	13
183702-81451	28	15
183702-91050	18	33
183702-91091	18	40
183702-92150	27	9
183702-92160	27	10
183702-92190	27	12
183702-93050	22	18
183702-93060	22	19
183702-93070	22	20
183702-93200	24	1
183702-93210	24	6
183702-93220	24	5

Parts No.	Fig. No.	Ref. No.
183702-93230	24	2
183702-93240	24	3
183702-93250	24	4
183702-93511	22	4
183702-93520	22	5
183702-93531	22	6
183702-93540	22	7
	23	6
183702-93550	22	8
	23	7
183702-93560	22	9
	23	8
183702-93571	22	10
183702-93590	22	17
	23	16
183702-93610	22	14
	23	13
183702-93620	22	15
	23	14
183702-93630	22	16
	23	15
183702-93650	22	12
	23	11
183702-93670	22	3
183702-93700	22	21
183702-93710	22	22
183702-93750	24	7
183702-93830	22	11
	23	10
183702-93850	22	13
	23	12
183702-94252	22	31
	23	36
183702-94270	22	32
	23	37
183702-94280	22	33
	23	38
183702-95150	27	2
183702-95200	24	8
183702-95510	15	84
183702-95630	18	20
183702-95640	18	21
183702-95650	18	22
183702-95660	18	23
183702-95670	18	24
183702-95680	18	25
183702-95690	18	26
183702-95710	11	51
183702-95750	11	57
183702-95760	11	56

Parts No.	Fig. No.	Ref. No.
183702-95770	11	55
183702-95780	11	54
183702-95790	11	58
183702-95800	11	59
183702-95900	18	28
183703-08070-1	16	33
183703-08110	16	45
183703-08120-1	16	48
183703-08130	16	106
183703-08140-1	16	52
183703-08150-4	16	56
183703-08160-1	16	61
183703-08170-1	16	107
183703-08300-1	16	1
183703-08310-1	16	17
183703-08320-1	16	39
183703-08330-1	16	44
183703-08551-1	16	64
183703-08580	16	69
183703-08590	16	70
183703-08760	16	72
183703-08980	16	108
183703-08990	16	77
183703-13510	5	28
183703-13710	5	29
183703-13720	5	32
183703-45060	12	10
183703-45080	12	9
183703-45090	12	11
183703-56900	18	1
	19	1
183703-74500	19	35
183703-76060	12	25
183703-76260	12	26
183703-76600	12	38
183703-76610	12	39
183703-78060	12	41
183703-78550	12	45
183703-81111	29	6
183703-81121	29	7
183703-81131	29	8
183703-81300	29	13
183703-81410	29	14
183703-81450	29	15
183703-81471	29	16
183703-81500	29	17
183703-81990	29	18
183703-85790	12	17
183703-91050	19	34
183703-91720	19	10



## Parts No. Index

Parts No.	Fig. No.	Ref. No.
183703-91730	19	11
183703-92190	27	13
183703-92700	21	4
183703-93050	23	18
183703-93090	23	19
183703-93110	23	20
183703-93130	23	21
183703-93150	23	22
183703-93200	25	1
183703-93210	25	2
183703-93220	25	4
183703-93230	25	5
183703-93240	25	3
183703-93510	23	3
183703-93520	23	4
183703-93530	23	5
183703-93570	23	9
183703-93590	23	1
183703-93700	23	23
183703-93710	23	24
183703-93760	23	25
183703-93770	23	26
183703-94050	22	25
183703-94400	22	34
	23	39
183703-95150	27	3
183703-95201	25	7
183703-95300	25	9
183703-95510	16	88
183703-95530	16	89
183703-95540	15	108
	16	118
183703-95601	25	10
183703-95620	19	20
183703-95630	19	21
183703-95640	19	23
183703-95650	19	24
183703-95670	19	25
183703-95680	19	26
183703-95690	19	27
183703-95710	12	14
183703-95740	12	18
183703-95750	12	19
183703-95760	12	20
183703-95770	12	15
183703-95780	12	16
183703-95900	19	28
183703-95920	19	29
183705-08900	15	107

Parts No.	Fig. No.	Ref. No.
183730-07420	14	27
183730-07430	14	15
183730-07470	14	18
183730-74950	17	19
		40
183730-91450	18	8
183731-07450	14	16
183732-08900	15	66
		67
		114
	16	74
183732-08910	15	69
		70
183732-45540	11	16
183732-95500	18	11
	19	12
183732-95510	18	15
	19	16
183732-95750	11	52
183732-95760	11	53
183820-74240	17	33
183833-08490	15	55
	16	63
183833-45200	12	12
183860-74410	17	15
		36
183920-79560	16	115
183920-91280	19	9
183920-91320	18	7
	19	6
183920-91450	19	7
183925-91990	15	82
		83
		92
	16	87
183932-79950	16	117
183933-79510	16	112
183934-74152	17	41
183976-78850	18	41
	19	41
183982-74430	17	37
194250-51660	5	26
194440-51620	7	28
194990-22150	28	2
	29	1
198220-62410	15	106
	16	80
1E6460-91573	15	76
		77
	16	84

Parts No.	Fig. No.	Ref. No.
1E6460-91580	15	78
		79
	16	85
1E6460-91591	15	80
		81
	16	86
1E6570-65750	28	3
	29	3
1E6770-91500	16	83
1E6910-35660	15	73
		74
	16	78
22117-100000	28	16
22117-120000	15	85
22137-040000	10	34
22137-060000	3	24
	15	86
22137-160000	6	47
	26	36
22217-030000	15	87
		88
		91
	16	90
22217-060000	17	16
		38
22217-080000	17	17
		42
22217-100000	23	27
22242-000120	28	17
	29	30
22252-000160	6	26
	26	7
22252-000190	6	56
	26	26
22312-060250	28	18
	29	19
22360-060000	28	19
	29	20
22372-080000	10	10
	28	20
	29	21
22417-320250	15	89
22417-400360	16	91
22512-040120	6	17
	26	17
22512-040160	6	18
		45
	26	18
		34
		21

Parts No.	Fig. No.	Ref. No.
22512-040160	29	22
22512-040300	6	46
	26	35
23000-035000	5	5
23112-040000	22	39
	23	44
23131-020000	22	36
	23	41
23171-020000	22	37
	23	42
24101-062050	1	6
		12
	20	6
		13
24101-062060	2	8
		12
	21	8
		14
24311-000180	1	17
		24
	2	17
		20
	20	17
		20
	21	18
		21
24550-014120	28	29
	29	23
26013-060222	28	23
26023-040142	17	20
		39
26106-060082	7	19
26106-060102	7	25
	11	18
	12	21
	15	104
		111
	24	9
26106-060122	11	11
		19
	12	22
	16	92
	22	35
	23	40
	28	22
		30
	29	24
		25
26106-060142	15	116
26106-060202	3	18

## Parts No. Index

Parts No.	Fig. No.	Ref. No.
26106-060302	6	29
	26	11
26106-060352	3	19
	4	19
26106-060402	5	33
26106-060552	12	40
26106-080142	5	10
		30
	7	9
	12	23
	15	105
	16	93
		98
	25	11
	28	24
		25
	29	27
26106-080202	15	112
	16	71
	28	26
	29	31
26106-080252	23	45
	29	26
26106-080302	2	14
26106-080352	15	93
	16	94
26106-080382	16	95
	22	23
26106-100202	28	27
	29	28
26106-100252	29	29
26106-100302	13	19
26116-080302	15	94
26117-040088	8	23
	9	22
	10	20
26117-040257	10	29
26117-040357	10	30
26216-080182	3	15
	4	16
26226-080182	4	16 -1
26226-080802	5	25
26226-100902	21	5
26347-040002	10	35
26347-060002	10	36
26366-060002	5	6
		34
	10	38
		41
		44

Parts No.	Fig. No.	Ref. No.
26366-080002	5	11
		24
		31
	15	95
	16	96
26366-100002	4	23
	15	96
	23	28
26450-080302	22	24
	23	29
26476-060142	1	21
	2	23
	10	48
	11	3
		4
		10
		20
	12	4
		5
		6
		24
		48
	20	23
	21	28
	24	10
	25	8
	27	4
		14
26476-060202	15	103
26476-060252	1	18
	12	49
	20	14
	21	15
26476-060302	11	30
26557-030062	18	30
	19	31
26557-030082	15	90
		97
		98
26557-030122	16	97
	18	6
	19	3
26557-040062	18	31
	19	32
26557-040102	10	37
	15	99
	16	99
	22	38
	23	43
26557-050082	15	100

Parts No.	Fig. No.	Ref. No.
26557-050082	16	100
26557-060122	12	58
26557-060222	11	28
	12	50
26577-060122	11	27
26696-100002	16	101
26712-100002	15	101
	16	102
26737-160002	6	48
	26	37
26757-040002	18	32
	19	33
26757-100002	15	102
	16	103
27310-060001	3	23
28110-100120	14	44
29610-000650	11	31
	12	51
29610-000950	11	36
	12	56
720380-11570	4	26
760690-23700	6	27
	26	9
760694-01501	1	10
760694-21700	6	13
760699-01640	1	1
760699-21720	26	13
760780-22530	6	21
760890-23700	6	57
	26	27
760994-01520	2	9
760998-21710	6	41
	26	30
760998-22530	6	51
783432-55700	7	1
783702-01511	20	10
783702-01640	20	1
783702-22500	26	3
783702-22720	26	1
783703-01510	21	11
783703-01640	21	1
783703-22501	26	21
783703-22721	26	19
783932-01560	2	1
X2114274200	13	18
X2114275010	13	15
X2114455080	13	11
X2114560130	13	14
X2114680050	13	16
X2114715500	13	4

Parts No.	Fig. No.	Ref. No.
X2114811000	13	3